

38" Lawn Tractor

Operating Manual

Model No. TMO-3394704

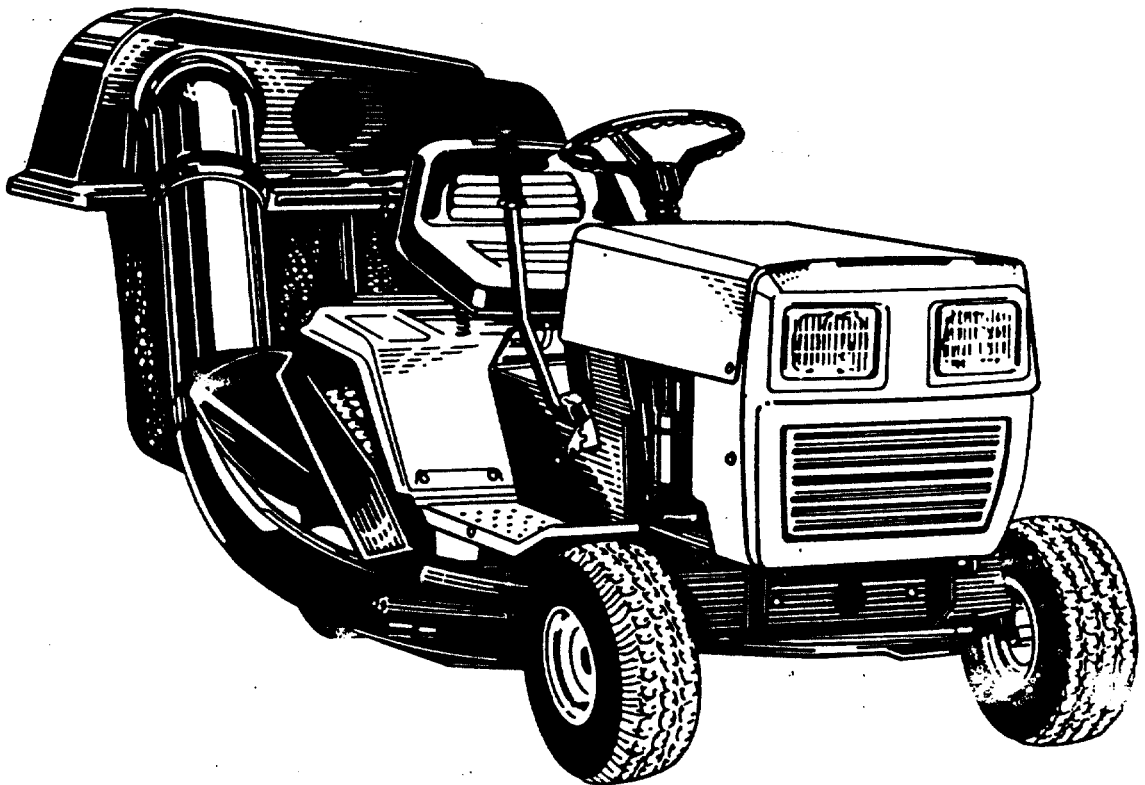

Montgomery Ward



INDEX

Slope Gauge	3
Contents of Hardware Pack	4
Safe Operation Practices	5
Assembly Instructions	6
Controls	9
Operation	10
Adjustments	11
Lubrication	14
Maintenance	14
Off-Season Storage	18
Trouble Shooting Guide	19, 20
Electrical System	21
Illustrated Parts for Lawn Tractor	22-33
Parts Information	Back Cover

Dear Customer,

So often throughout the year we are all in a rush to meet our daily obligations.

However, we at Montgomery Ward are taking a quick moment out to say...

"Thank you for your business."

Sincerely,
MONTGOMERY WARD



INSTRUCTIONS GIVEN WITH THIS SYMBOL ARE FOR PERSONAL SAFETY. BE SURE TO FOLLOW THEM.

NOTICE: A data plate with the model numbers and serial numbers of your unit is located on the frame, under the seat. Record these numbers in the spaces provided on the back cover of this guide.

BEFORE YOU CALL SERVICE

Check Spark Plug Wire

- Firmly attached?
- Wire terminal clean?

Check Crankcase Oil Level

- Overfilled/underfilled?

Check Fuel Tank

- Fuel in tank?
- Fuel dirty or stale?
- If tank has been empty for a long period, fill tank completely.

Check Air Cleaner

- Clean?
- Choke plate stuck?
- Governor spring free to move?

Check under Blade Housing (**Disconnect Spark Plug First**)

- Blade obstructed or bent?

Check Starting Instructions

- Read instruction manuals and labels for specific instructions.

WARNING: This unit is equipped with an internal combustion engine and should not be used on or near any unimproved forest-covered, brush-covered or grass-covered land unless the engine's exhaust system is equipped with a spark arrester meeting applicable local or state laws (if any). If a spark arrester is used, it should be maintained in effective working order by the operator.

In the State of California the above is required by law (Section 4442 of the California Public Resources Code). Other states may have similar laws. Federal laws apply on federal lands. A spark arrester for the muffler is available. Contact the parts sales center of Montgomery Ward.

Cut Along This Line

USE THIS SHEET AS A GUIDE TO DETERMINE SLOPES WHERE YOU MAY NOT OPERATE SAFELY.

SLOPE GAUGE

(Keep this sheet in a safe place for future reference.)

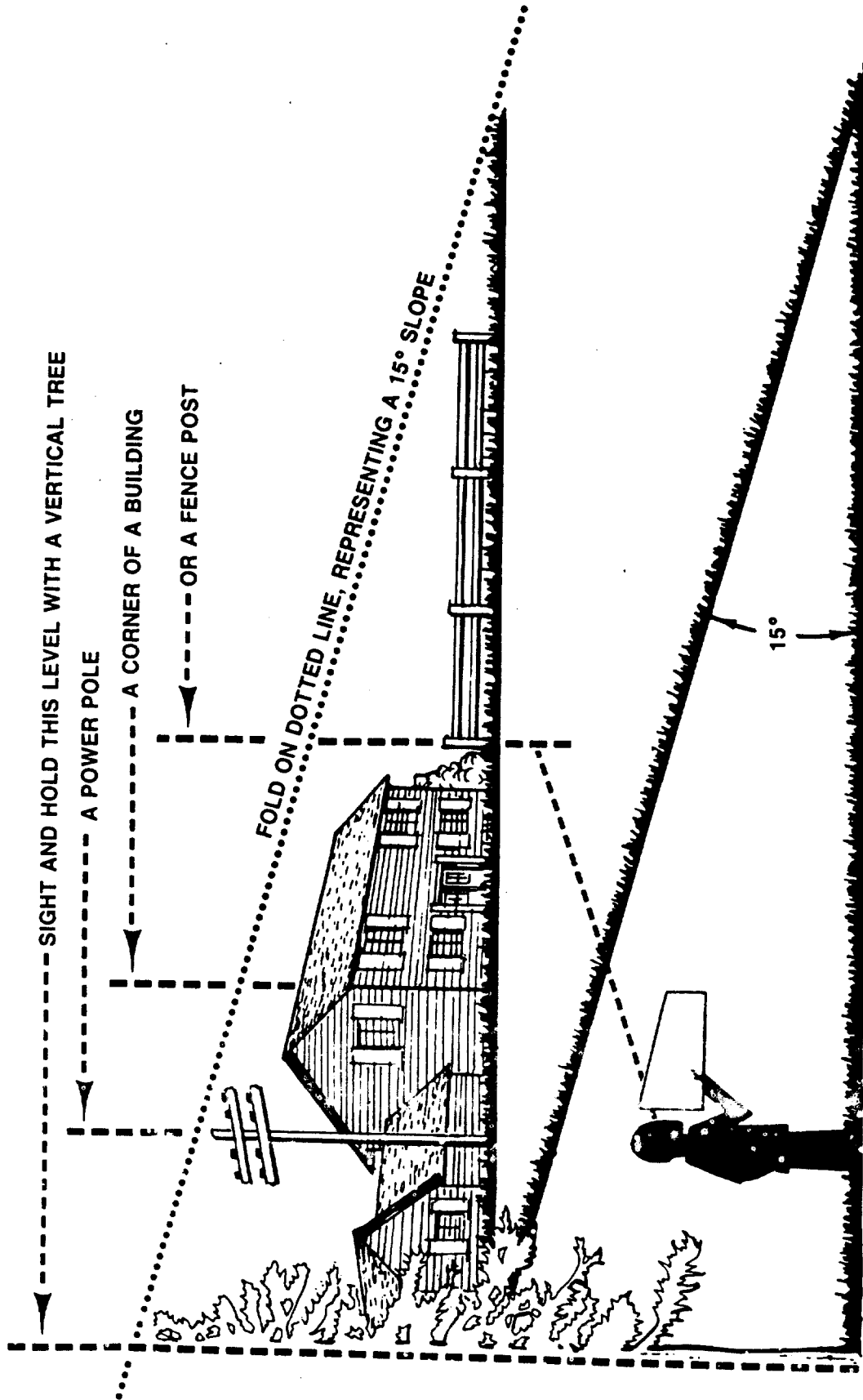

Do not mow on inclines with a slope in excess of 15 degrees (a rise of approximately 2-1/2 feet every 10 feet). A riding mower could overturn and cause serious injury. If operating a walk-behind mower on such a slope, it is extremely difficult to maintain your footing and you could slip, resulting in serious injury.

Operate **HIDING** mowers up and down slopes, never across the face of slopes.
Operate **WALK-BEHIND** mowers across the face of slopes, never up and down slopes.

CONTENTS OF HARDWARE PACK

Remove this sheet from your owner's manual and lay the hardware on the illustration for identification purposes. After assembly, keep the Slope Gauge which is on the reverse side of this sheet for future use.

(Hardware pack may contain extra items which are not used on your unit.)

A INSTALLING THE BATTERY

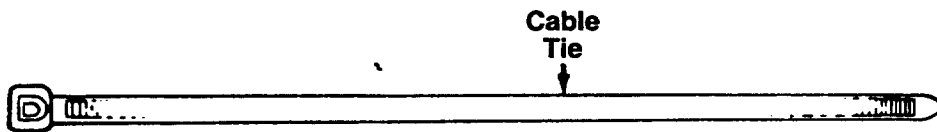

B ATTACHING THE STEERING WHEEL

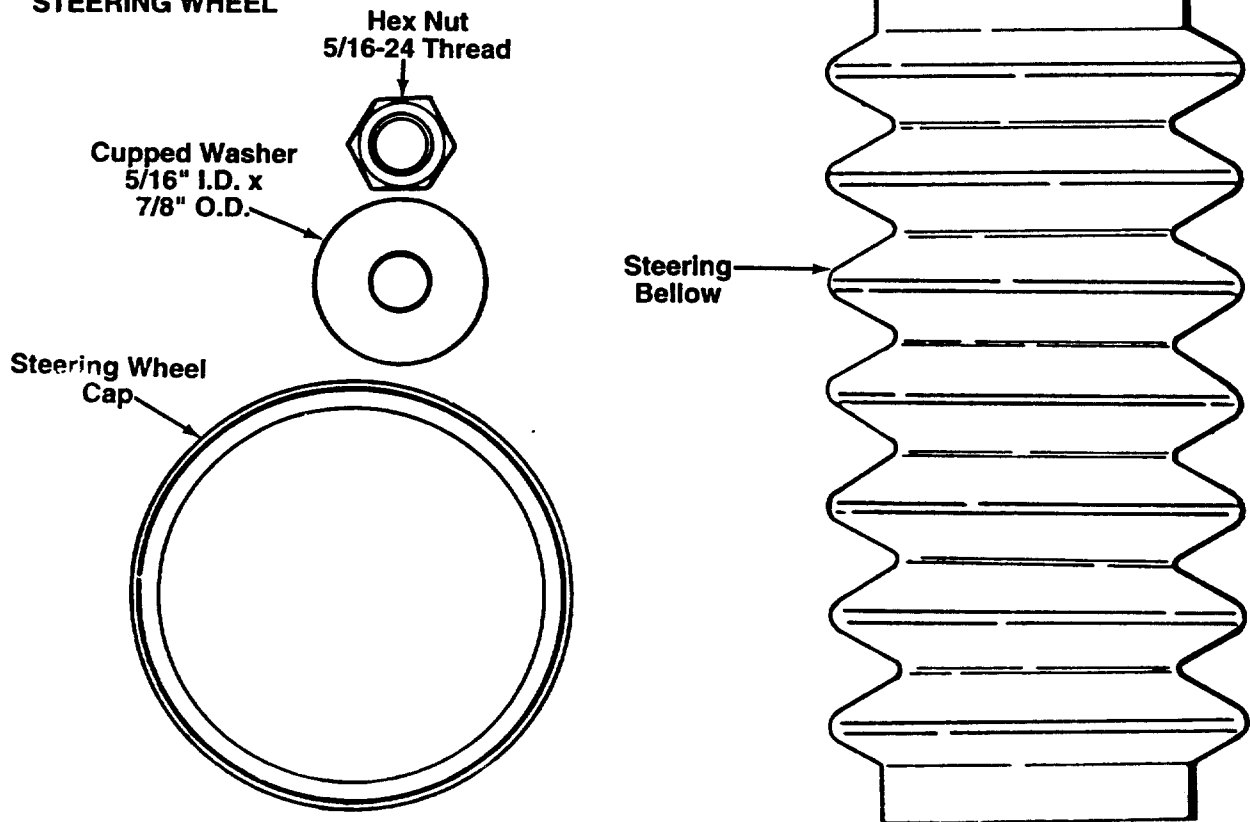

C IGNITION KEYS

(May Be
Attached to
Tractor)

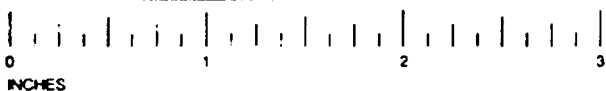
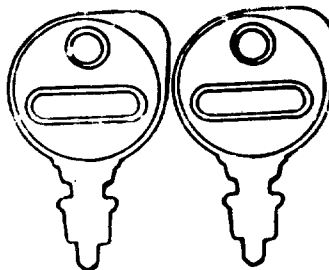

INCHES

IMPORTANT

SAFE OPERATION PRACTICES



THIS SYMBOL POINTS OUT IMPORTANT SAFETY INSTRUCTIONS WHICH, IF NOT FOLLOWED, COULD ENDANGER THE PERSONAL SAFETY AND/OR PROPERTY OF YOURSELF AND OTHERS. READ AND FOLLOW ALL INSTRUCTIONS IN THIS MANUAL BEFORE ATTEMPTING TO OPERATE YOUR UNIT. WHEN YOU SEE THIS SYMBOL—  **HEED ITS WARNING.**



DANGER: This cutting machine is capable of amputating hands and feet and throwing objects. Failure to observe the following safety instructions could result in serious injury or death.

I. GENERAL OPERATION

1. Read, understand, and follow all instructions in the manual and on the machine before starting. Keep this manual in a safe place for future reference and for ordering replacement parts.
2. Only allow responsible adults familiar with the instructions to operate the machine. Know controls and how to stop the machine quickly.
3. Do not put hands or feet under cutting deck or near rotating parts.
4. Clear the area of objects such as rocks, toys, wire, etc. which could be picked up and thrown by the blade. A small object may have been overlooked and could be accidentally thrown by the mower in any direction and cause injury to you or a bystander. Always wear safety glasses or eye shields during operation or while performing an adjustment or repair, to protect eyes from foreign objects. Stop the blade(s) when crossing gravel drives, walks or roads.
5. Be sure the area is clear of other people before mowing. Stop machine if anyone enters the area.
6. Never carry passengers.
7. Disengage blade(s) before shifting into reverse and backing up. Always look down and behind before and while backing.
8. Be aware of the mower and attachment discharge direction and do not point it at anyone. Do not operate the mower without either the entire grass catcher or the chute guard in place.
9. Slow down before turning. Operate the tractor smoothly. Avoid erratic operation and excessive speed.
10. Never leave a running machine unattended. Always turn off blade(s), place transmission in neutral, set park brake, stop engine and remove key before dismounting.
11. Turn off blade(s) when not mowing.
12. Stop engine and wait until blade(s) comes to a complete stop before (a) removing grass catcher or unclogging chute, or (b) making any repairs, adjusting or removing any grass or debris.
13. Mow only in daylight or good artificial light.
14. Do not operate the machine while under the influence of alcohol or drugs.
15. Watch for traffic when operating near or crossing roadways.
16. Use extra care when loading or unloading the machine into a trailer or truck. This unit should not be driven up or down a ramp onto a trailer or truck under power, because the unit could tip over, causing serious personal injury. The unit must be pushed manually to load or unload properly.
17. Never make a cutting height adjustment while engine is running if operator must dismount to do so.
18. Wear sturdy, rough-soled work shoes and close-fitting slacks and shirts. Do not wear loose fitting clothes or jewelry. They can be caught in moving parts. Never operate a unit in bare feet, sandals, or sneakers.
19. Check overhead clearance carefully before driving under power lines, wires, bridges or low hanging tree branches, before entering or leaving buildings, or in any other situation where the operator may be struck or pulled from the unit, which could result in serious injury.
20. Disengage all attachment clutches, thoroughly depress the brake pedal, and shift into neutral before attempting to start engine.

II. SLOPE OPERATION

Slopes are a major factor related to loss of control and tip-over accidents which can result in severe injury or death. All slopes require extra caution. If you cannot back up the slope or if you feel uneasy on it, do not mow it.

DO:

- Mow up and down slopes, not across.
- Remove obstacles such as rocks, limbs, etc.
- Watch for holes, ruts or bumps. Uneven terrain could overturn the machine. **Tall grass can hide obstacles.**
- Use slow speed. Choose a low enough gear so that you will not have to stop or shift while on the slope. Always keep tractor in gear when going down slopes to take advantage of engine braking action.
- Follow the manufacturer's recommendations for wheel weights or counterweights to improve stability.
- Use extra care with grass catchers or other attachments. These can change the stability of the machine.
- Keep all movement on the slopes **slow and gradual**. Do not make sudden changes in speed or direction. Rapid engagement or braking could cause the front of the machine to lift and rapidly flip over backwards which could cause serious injury.
- Avoid starting or stopping on a slope. If tires lose traction, disengage the blade(s) and proceed slowly **straight** down the slope.
- For your safety, use the slope gauge included as part of this manual to measure slopes before operating this unit on a sloped or hilly area. If the slope is greater than 15° as shown on the slope gauge, do not operate this unit on that area or serious injury could result.

DO NOT:

- Do not turn on slopes unless necessary; then, turn slowly and gradually downhill, if possible.
- Do not mow near drop-offs, ditches or embankments. A wheel over the edge or an edge caving in could cause sudden overturn.
- Do not mow on wet grass. Reduced traction could cause sliding.
- Do not try to stabilize the machine by putting your foot on the ground.
- Do not use grass catcher on steep slopes.

III. CHILDREN

Tragic accidents can occur if the operator is not alert to the presence of children. Children are often attracted to the machine and the mowing activity. **Never** assume that children will remain where you last saw them.

1. Keep children out of the mowing area and in watchful care of an adult other than the operator.
2. Be alert and turn machine off if children enter the area.
3. Before and when backing, look behind and **down** for small children.
4. Never carry children. They may fall off and be seriously injured or interfere with the safe machine operation.
5. Never allow children under 14 years old to operate the machine. Children 14 years and over should only operate machine under close parental supervision and proper instruction.
6. Use extra care when approaching blind corners, shrubs, trees or other objects that may obscure vision.

IV. SERVICE

1. Use extra care in handling gasoline and other fuels. They are flammable and vapors are explosive.
 - a. Use only an approved container.
 - b. Never remove gas cap or add fuel with the engine running. Allow engine to cool at least two minutes before refueling. Do not smoke.
 - c. Never refuel the machine indoors.
 - d. Never store the machine or fuel container inside where there is an open flame, or spark, such as a water heater, space heater, clothes dryer and the like.
2. Never run a machine inside a closed area.
3. Check frequently and keep nuts and bolts, especially blade attachment bolts, tight and keep equipment in safe working condition.
4. Never tamper with safety devices. Check their proper operation regularly. Use all guards as instructed in this manual.
5. To reduce fire hazard, keep machine free of grass, leaves or

other debris build-up. Clean up oil or fuel spillage. Allow machine to cool before storing.

6. Stop and inspect the equipment for damage if you strike an object. Repair, if necessary, before re-starting and operating the machine.
7. Never make adjustments or repairs with the engine running.
8. Grass catcher components are subject to wear, damage and deteriorate, which could expose moving parts or allow objects to be thrown. Frequently, check components and replace with manufacturer's recommended parts when necessary.
9. Mower blades are sharp and can cut. Wrap the blade(s) or wear gloves and use extra caution when servicing blade(s).
10. Check brake operation frequently. Adjust and service as required.
11. Muffler, engine, and belt guards become hot during operation and can cause a burn. Allow to cool down before touching.
12. Do not change the engine governor settings or overspeed the engine.



DANGER: Your unit was built to be operated according to the rules for safe operation in this manual. As with any type of power equipment, carelessness or error on the part of the operator can result in serious injury. If you violate any of these rules, you may cause serious injury to yourself or others.

ASSEMBLY INSTRUCTIONS

IMPORTANT: After assembly, service engine with gasoline, and check oil level as instructed in the engine section of this manual.

NOTE: Reference to right or left hand side of the unit is observed from the driver's seat, facing forward.

UNPACKING

1. Remove the lawn tractor from the carton as follows. Open the top flaps. Remove all loose parts and carton inserts. Cut the front corners of the carton. Make certain brake is released, and push the unit out of the carton.
2. Remove page four from this manual and lay the contents of the hardware pack on the illustration for identification.

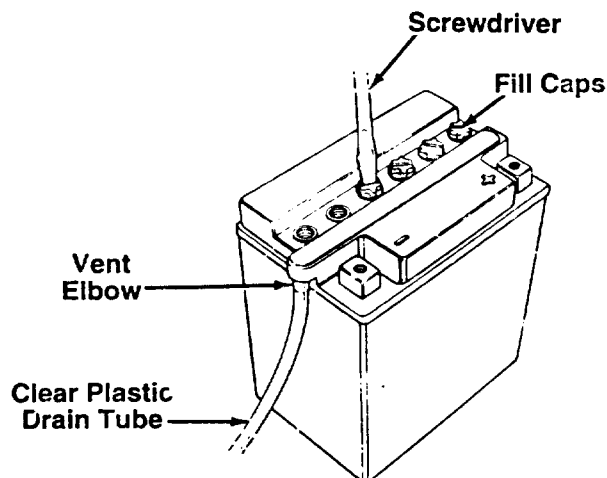

FIGURE 1.

BATTERY INFORMATION



WARNING

- A. Battery acid must be handled with great care as contact with it can burn and blister the skin. It is also advisable to wear protective clothing (goggles, rubber gloves and apron) when working with it.*
- B. Should battery acid accidentally splatter into the eyes or onto the face, rinse the affected area immediately with clean cold water. If there is any further discomfort, seek prompt medical attention.
- C. If acid spills on clothing, first dilute it with clean water, then neutralize with a solution of ammonia/water or baking soda/water.
- D. Since battery acid is corrosive, do not pour it into any sink or drain. Before discarding empty electrolyte containers, rinse them with a neutralizing solution.
- E. NEVER connect or disconnect charger clips to battery while charger is turned on as it can cause sparks.
- F. Keep all lighted materials (cigarettes, matches, lighters) away from the battery as the hydrogen gas generated during charging can be combustible.
- G. As a further precaution, only charge the battery in a well-ventilated area.
*Always shield eyes, protect skin and clothing when working near batteries.

ACTIVATING THE BATTERY

Do not activate battery (fill with battery acid) until battery is actually placed in service. Be certain to read previous warnings before activating the battery.

1. Open the battery box (located under the seat) by pressing in on the end (right hand side) and lifting up. Remove the battery. The clear plastic drain tube should be attached to the battery.
2. Open the battery pack. Be careful not to puncture the box. It contains the battery fluid (acid) in a plastic container and one short plastic tube.

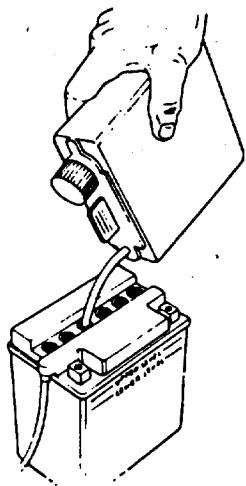



FIGURE 2.



DANGER

Battery contains sulfuric acid. Refer to warning on page 6. Antidote: EXTERNAL—Flush with water. INTERNAL—Drink large quantities of water or milk. Follow with milk of magnesia, beaten eggs or vegetable oil. Call physician immediately. EYES: Flush with cool water for at least 15 minutes, then get prompt medical attention.

Since batteries produce explosive gases, keep all lighted materials (cigarettes, lighters, matches, etc.) away. Be sure to charge battery only in well-ventilated areas. Make certain venting path of battery (drain tube) is always open.

**KEEP BATTERIES
OUT OF THE REACH OF CHILDREN!**

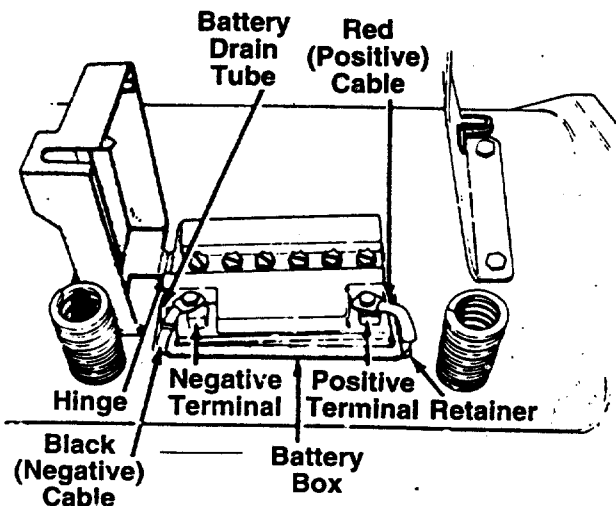

FIGURE 3.

3. Place the battery on a table or workbench. Make certain the long plastic drain tube is in place on the vent elbow.
4. Remove the six fill caps from the top of the battery with a screwdriver. Be careful not to damage the fill caps. See figure 1.
5. Place the battery fluid container on the table or workbench. Carefully cut off tip of the spout and attach the short plastic tube provided. Do not squeeze the container when cutting tip.
6. Fill each battery cell slowly and carefully to the UPPER LEVEL line marked on battery. See figure 2. Use caution as the acid level will rise rapidly after the bottom of the cell is filled.
7. Allow battery to stand for 30 minutes with the fill caps removed, while the plates absorb acid.
8. If acid level has fallen after the 30 minute standing period, refill each cell with battery acid to the UPPER LEVEL line on battery. Replace the fill caps.
9. Before discarding the empty container, neutralize any residue with baking soda and rinse container with water. Puncture container several times before discarding.
10. Charge the battery after the 30 minute standing period. **SLOW CHARGE THE BATTERY (DO NOT FAST CHARGE)** at a maximum bench rate of 1.4 amperes until the specific gravity reading is 1.260-1.280. Charge for a minimum of 2 hours and a maximum of 8 hours.

NOTE: This engine is equipped with an alternator. The current for the battery charger alternator is unregulated. During normal operation, it is only necessary to charge the battery:

1. When it is activated for the first time.
2. Before winter storage.
3. Before using the lawn tractor after winter storage.

NOTE: Charging rate after battery has been put into operation—the battery is to be charged for a period of 14-16 hours. **NO LONGER THAN 30 HOURS.**

After battery has been charged, add only distilled water. Do not add acid.

INSTALLING THE BATTERY (Hardware A)

1. Lift the seat.
2. Make certain the positive cable (heavy red wire) extends through the retainer on the right side of the battery box. The negative cable (heavy black wire) should be routed up along the left side of the battery box.
3. Place the battery inside the battery box so that the positive terminal is toward the right side of the unit. See figure 3. Route the battery drain tube down beside the battery box.
4. Remove the bolt on the positive terminal of the battery. Place the positive (+) red cable on the terminal. Secure with the bolt. Be careful not to lose the nut which is inside the terminal.
5. Attach the negative (-) black cable in the same manner.

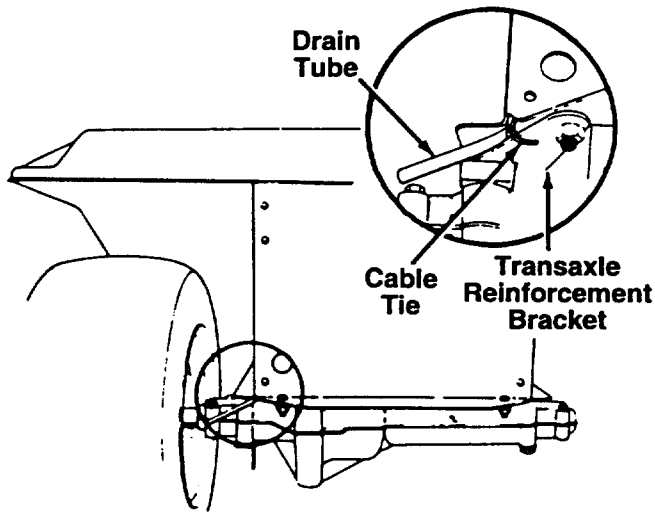

FIGURE 4.

6. Route the drain tube through the opening between the transaxle reinforcement bracket and the frame on the left rear of the unit. Insert the drain tube to the transaxle reinforcement bracket through the cable tie which is attached as shown in figure 4. Be certain drain tube is routed away from the wheel rim. Trim excess end of cable tie and drain tube (leave approximately 1" below lawn tractor frame).
7. Close the top of the battery box.

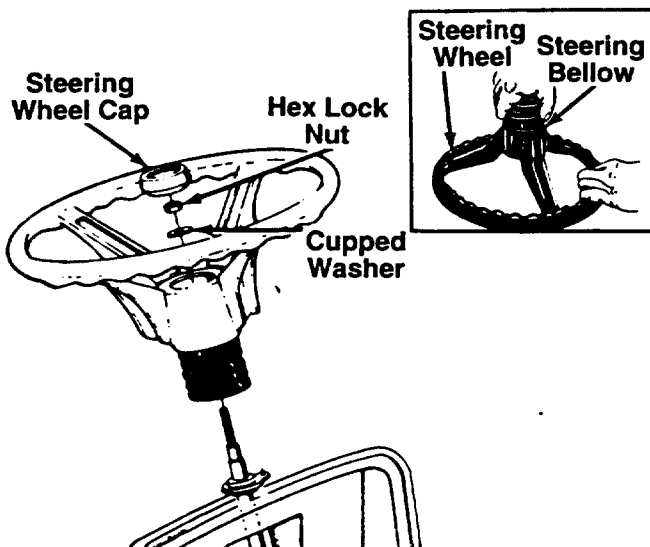

FIGURE 5.

ATTACHING THE STEERING WHEEL (Hardware B)

1. Attach one end of steering bellow to the steering wheel as shown in figure 5, inset.
2. With the wheels of the tractor pointing straight forward, place the steering wheel and steering bellow over the steering shaft, positioning steering wheel as desired.
3. Place the washer with the cupped side down over the steering shaft. Secure with 5/16" hex lock nut. See figure 5.
4. Place the steering wheel cap over the center of the steering wheel and seat it with your hand.

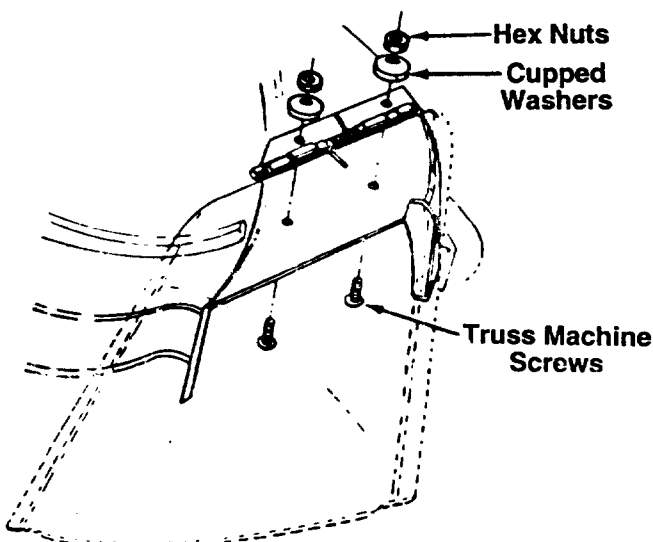

FIGURE 6.

ATTACHING THE CHUTE DEFLECTOR

1. Remove the truss machine screws, cupped washers and hex jam nuts which are attached to the deck next to the chute opening.
2. Place the chute deflector in position as shown in figure 6. Secure with hardware just removed



WARNING: Do not operate your unit unless the chute deflector has been properly installed.

CONTROLS

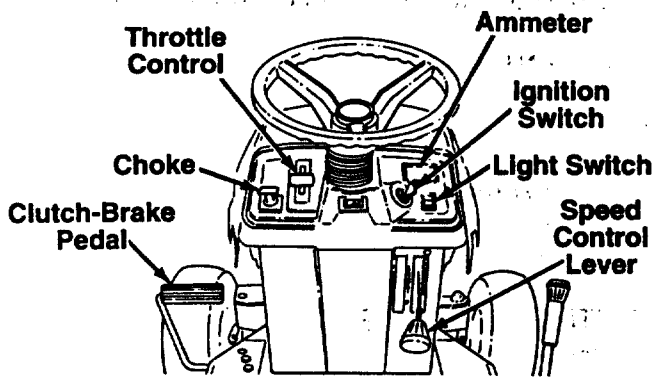

FIGURE 7.

THROTTLE CONTROL

The throttle control is used to regulate the engine speed. To get maximum efficiency from cutting, the throttle should be in the FAST position when operating the mower. See figure 7.

CHOKE CONTROL

The choke control is located on the dashboard and is operated manually. Details for the choke operation are covered in the separate engine manual. See figure 7.

SPEED CONTROL LEVER

The speed control lever allows you to regulate the ground speed of the lawn tractor. See figure 7. To select the ground speed, depress clutch pedal. Push speed control lever inward and move downward to slow lawn tractor, move upward to increase speed. When desired speed has been obtained, release lever in that position. Whenever clutch is engaged, unit will automatically go to the pre-set speed.

IGNITION SWITCH

Turn the key to the START position to start the engine. When the engine is running, let the key return to the ON position. To stop the engine, turn the key to the left to the OFF position and remove it to prevent accidental starting. See figure 7.

LIGHT SWITCH

Push the light switch to turn on the lights. The lights will only operate when the engine is running. See figure 7.

SHIFT LEVER

The shift lever is located on the left fender and has three positions, FORWARD, NEUTRAL and REVERSE. See figure 8. The clutch-brake pedal must be depressed and the lawn tractor must not be moving when shifting gears. Do not force the shift lever. Release the clutch-brake pedal slightly to line up the shifting collar in the transmission. Then try to shift gears.

CLUTCH-BRAKE PEDAL

The clutch-brake pedal is located on the left side of the lawn tractor. Depressing the clutch-brake pedal part way disengages the clutch. Pressing the pedal all the way down disengages the clutch and engages the disc brake. See figure 7.

NOTE: The clutch-brake pedal must be depressed to start the engine.

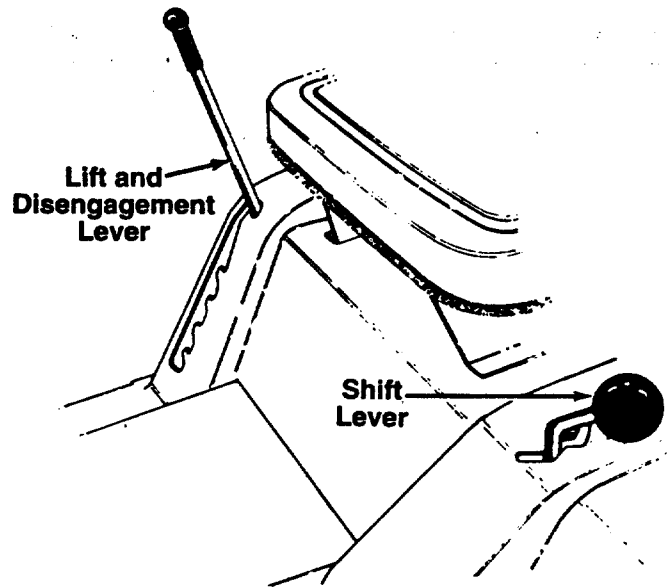

FIGURE 8.

PARKING BRAKE

The speed control lever is used to set the parking brake. To set the parking brake, depress the clutch-brake pedal. Press the speed control lever inward and all the way down. Release the speed control lever and the clutch-brake pedal.

To release the parking brake, depress the clutch-brake pedal, press the speed control lever inward and move to desired position. Release the speed control lever and the clutch-brake pedal.

NOTE: The parking brake must be set if the operator leaves the seat with the engine running.

LIFT AND DISENGAGEMENT LEVER

The lift and disengagement lever is used to raise and lower the cutting deck which determines the cutting height. Pulling it all the way back and locking it disengages the blades. The lift and disengagement lever must be in the disengaged position when starting the engine, when shifting into reverse or if the operator leaves the seat. See figure 8.

AMMETER

The ammeter registers the rate of battery charge or discharge. The ammeter will register on the discharging side when starting the engine. It should register on the opposite side (charging) when the engine is running in the fast position until the battery is completely charged. With a fully charged battery or with the engine idling, the ammeter will not show a charge.

INTERLOCKS (Not Shown)

Interlock safety switches are located by the clutch-brake pedal, the lift and disengagement lever, the shift lever and under the seat.

Before the engine will start, the clutch-brake pedal must be depressed all the way and the lift and disengagement lever must be in the disengaged position.

Before the unit can be shifted into reverse or if the operator leaves the seat, the lift and disengagement lever must be in the disengaged position.

OPERATION



WARNING

AVOID SERIOUS INJURY OR DEATH

- GO UP AND DOWN SLOPES, NOT ACROSS. • AVOID SUDDEN TURNS.
- DO NOT OPERATE THE UNIT WHERE IT COULD SLIP OR TIP.
- IF MACHINE STOPS GOING UPHILL, STOP BLADE(S) AND BACK DOWNHILL SLOWLY.
- DO NOT MOW WHEN CHILDREN OR OTHERS ARE AROUND.
- NEVER CARRY CHILDREN.
- LOOK DOWN AND BEHIND BEFORE AND WHILE BACKING.
- KEEP SAFETY DEVICES (GUARDS, SHIELDS, AND SWITCHES) IN PLACE AND WORKING.
- REMOVE OBJECTS THAT COULD BE THROWN BY THE BLADE(S).
- KNOW LOCATION AND FUNCTION OF ALL CONTROLS.
- BE SURE BLADE(S) AND ENGINE ARE STOPPED BEFORE PLACING HANDS OR FEET NEAR BLADE(S).
- BEFORE LEAVING OPERATOR'S POSITION, DISENGAGE BLADE(S), PLACE THE SHIFT LEVER IN NEUTRAL, ENGAGE BRAKE LOCK, SHUT ENGINE OFF AND REMOVE KEY.

READ OPERATOR'S MANUAL

TIRE PRESSURE

The tires on your unit may be over-inflated for shipping purposes. Reduce the tire pressure before operating the unit. Recommended operating tire pressure is approximately 12 p.s.i. (check sidewall of tire for tire manufacturer's recommended pressure).



WARNING: Maximum tire pressure under any circumstances is 30 p.s.i. Equal tire pressure should be maintained on all tires.

GAS AND OIL FILL-UP

NOTE: To open the hood, simply lift up on both sides of the hood.

Service the engine with gasoline, and check oil level as instructed in the separate engine manual packed with your unit. Read instructions carefully.

IMPORTANT: Your tractor is shipped with oil; however, you **must** check the oil level before operating and add if necessary. Be careful not to overfill.



WARNING: Never fill fuel tank indoors, with engine running or while engine is hot.

STARTING THE ENGINE

1. Depress the clutch-brake pedal and set the parking brake.
2. Place the lift and disengagement lever in the DISENGAGED position. See figure 8.

NOTE: This unit is equipped with a **safety interlock system** for your protection. The purpose of the safety interlock system is to prevent the engine from cranking or starting unless the clutch-brake pedal is depressed and the lift and disengagement lever is in the disengaged position. In addition, the lift and disengagement lever must be in the disengaged position when the unit is put into reverse or the engine will shut off. If the operator leaves the seat with the lift and disengagement lever engaged and/or without setting the parking brake, the engine will shut off.



WARNING: Do not operate the lawn tractor if the interlock system is malfunctioning because it is a safety device, designed for protection.

3. Set the throttle control in the FAST position. See figure 7.
4. Pull out choke knob to choke engine. (A warm engine may not require choking.)
5. Turn the ignition key to the START position. When the engine is running, let the key return to the ON position. See figure 7.
6. Push choke knob in gradually. Move the throttle control to desired engine speed.

STOPPING THE ENGINE

Turn the ignition key to the left to the OFF position. Remove the key to prevent accidental starting.

IMPORTANT: If you strike a foreign object, stop the engine. Remove wire from spark plug, thoroughly inspect the unit for any damage, and repair the damage before restarting and operating the mower.

NOTE: If any problems are encountered, refer to the *Trouble Shooting Guide* on page 19.

OPERATING THE LAWN TRACTOR

1. Start the engine as instructed previously.
2. Move throttle control to 3/4 or full throttle to prevent strain on the engine and to operate the cutting blades.
3. Place the shift lever in either the FORWARD or REVERSE position.



WARNING: Look to the rear before backing up.

4. Release the parking brake by depressing the clutch-brake pedal, pressing outward on the speed control lever and moving to desired position. Use first speed position when operating the lawn tractor for the first time.
5. Release clutch-brake pedal slowly to put unit into motion.
6. The lawn tractor is brought to a stop by depressing the clutch-brake pedal.

NOTE: When operating the unit initially, there will be little difference between the highest two speeds until after the belts have seated themselves into the pulleys during the break-in period. Be certain to change oil in the crankcase after the first 5 hours of operation.

Be sure that the lawn is clear of stones, sticks, wire, or other objects which could damage lawn tractor, or the debris could be thrown by the blade in any direction and cause an injury. For best results and to insure more even grass distribution, do not mow when lawn is excessively wet.



WARNING: Before leaving the operator's position for any reason, disengage the blades, place the shift lever in neutral, engage the parking brake, shut engine off and remove the key.

When stopping the unit to empty a grass bag, etc., follow the instructions above. This procedure will also eliminate "browning" the grass, which is caused by hot exhaust gases from a running engine.

If unit stalls with speed control in high speed, or if unit will not operate with speed control lever in a low speed position, proceed as follows.

1. Place shift lever in NEUTRAL.
2. Restart engine.
3. Place speed control lever in high speed position.
4. Release clutch-brake pedal fully.
5. Depress clutch-brake pedal.
6. Place speed control lever in desired position.
7. Place shift lever in either FORWARD or REVERSE, and follow normal operating procedures.

OPERATING THE CUTTING BLADES

The cutting blades may be engaged while the lawn tractor is moving or standing still. DO NOT engage the cutting blades abruptly as the sudden belt tension on the pulley may cause the engine to stall.



WARNING: When the blade drive is engaged, keep feet and hands away from the discharge opening, the blades or any part of the deck. When the unit is used for other than mowing, the blade drive should be disengaged.

Move the lift and disengagement lever into the DIS-ENGAGED position to raise the deck and disengage the blades.

ADJUSTMENTS

SEAT ADJUSTMENT

To adjust the position of the seat, loosen the four self-tapping screws on the bottom of the seat. See figure 9. Slide the seat forward or backward as desired. Retighten the self-tapping screws.

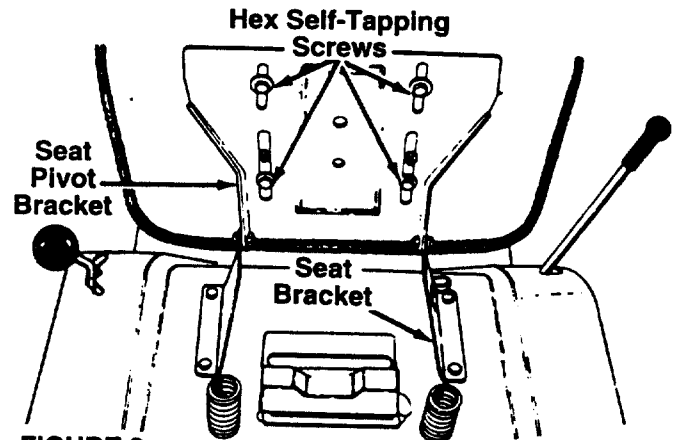

FIGURE 9.

DECK LEVELING ADJUSTMENT

If an uneven cut is obtained, the deck may be leveled as follows.

1. Move the lift and disengagement lever forward (lower the cutting deck).
2. With unit on hard, level surface, measure the distance from the bottom edge of the center of the left side of deck to the ground. Measure the same distance just behind the chute area on the right side of the deck. Or, place the blades in a straight line, and measure the distance from the outside edge of the blade tips to the ground.
3. Disconnect the adjustable deck links from the deck lift pivot brackets on the left side of the unit by removing the hairpin clips and flat washers. See figure 10.
4. Thread the adjustable links in or out as necessary. Reassemble the links. Check the adjustment, and readjust as necessary.

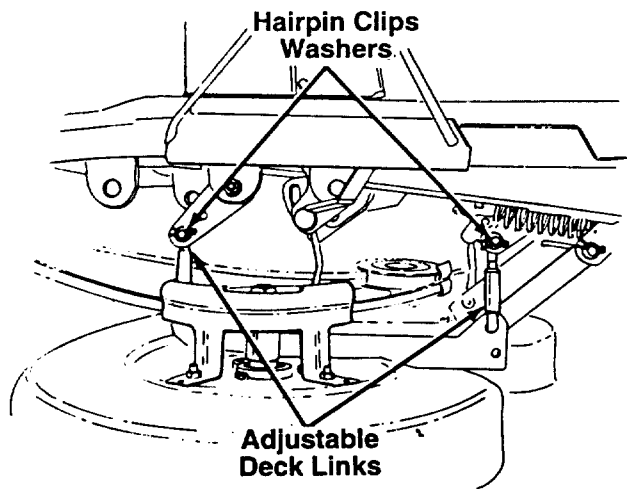

FIGURE 10.

SPEED CONTROL ADJUSTMENT (See Figure 11)

NOTE: When operating the unit initially or after replacing the belts, there will be little difference between the highest two speeds until after the belts have gone through a break-in period and have seated themselves into the pulleys.

First, adjust the speed control lever as follows:

1. Place the shift lever in Neutral position.
2. Start the engine.
3. Place the speed control lever in high speed position.
4. Release the clutch-brake pedal completely, then slowly depress the pedal all the way (to disengaged position). Hold the pedal in this position.
5. Turn the engine off.
6. After engine stops completely, release the clutch-brake pedal.
7. Disconnect the speed control link from the variable speed bracket by removing the hairpin clip and flat washer from the stud located on the bottom side of the variable speed bracket.
8. Depress the clutch-brake pedal forward until the stop on the clutch-brake pedal assembly hits solidly against the underside of the frame.
9. Remove the hairpin clip and flat washer from the rod attached to the back of the speed control lever.
10. Place the speed control lever in parking brake position.
11. Thread the ferrule on the rod until the ferrule slips into the bottom end of the slot in the speed control lever, then thread the ferrule down on the rod one full turn (to shorten).
12. Place speed control lever in first position.

13. Place ferrule into speed control lever slot, and secure with flat washer and hairpin clip. Release the clutch-brake pedal.

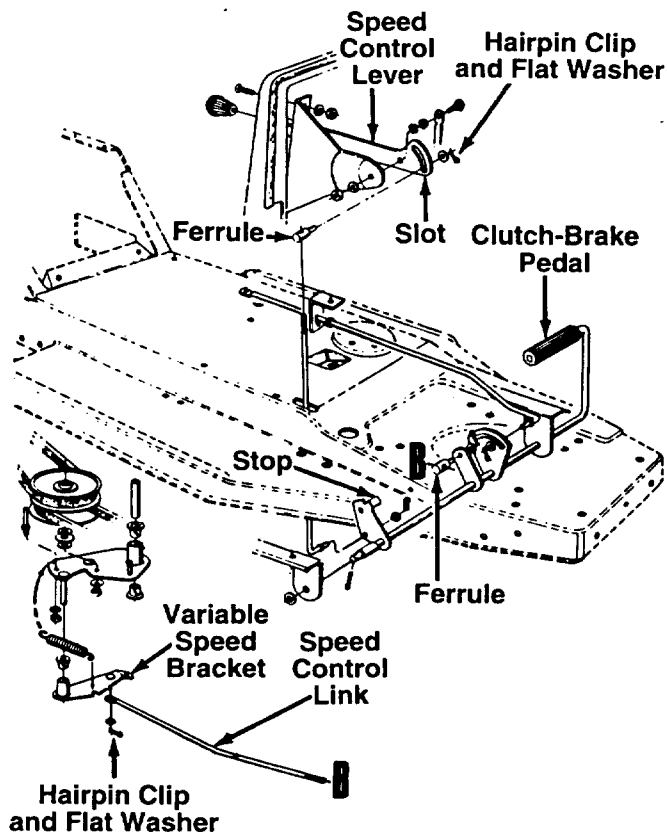

FIGURE 11.

Next, adjust the speed control link as follows to obtain the correct neutral adjustment.

1. Push the clutch-brake pedal backward by hand as far as it will go using light pressure. Hold it in this position as you make the following adjustment.
2. Thread the speed control link into or out of the ferrule until the eyelet on the opposite end of the link slips onto the stud on the bottom side of the variable speed bracket.
3. Secure the speed control link to the variable speed bracket with flat washer and hairpin clip.

NEUTRAL ADJUSTMENT (Wheel Drive)

1. Place the transmission in neutral. (The unit will move freely when pushed forward and backward with the parking brake released.)
2. Loosen the bolt which secures the shift lever assembly to the shift lever adjusting link. See figure 12.
3. Place the shift lever in the neutral slot. See figure 12.
4. Tighten the bolt to 13 foot pounds.

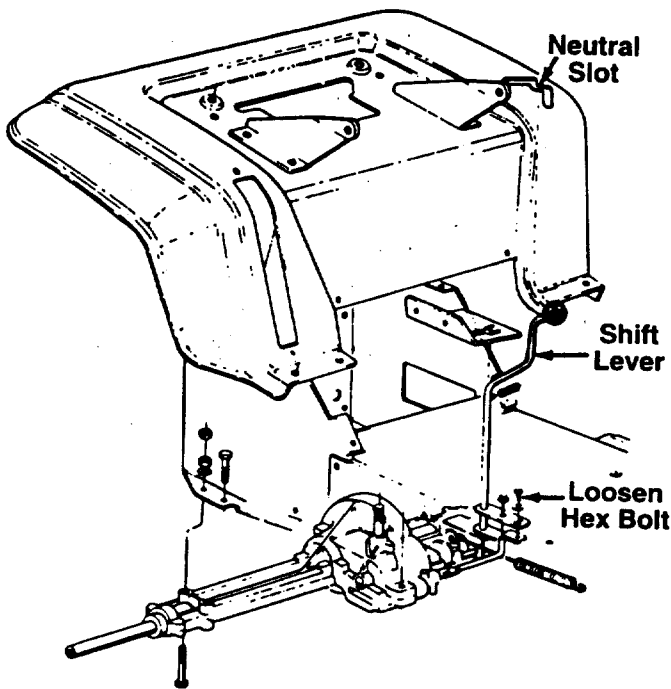

FIGURE 12.

CUTTING DECK ENGAGEMENT ADJUSTMENT

The cutting deck engagement may be adjusted to make certain deck is disengaged when lift and disengagement lever is in the disengaged position, or to obtain more drive in the cutting positions. Correct adjustment as follows.

Place the lift and disengagement lever in the highest cutting position (first notch down from disengaged position). The approximate adjustment is to have the lock nut on the threaded rod (above the rear of the deck) touching the end of the tubing. See figure 13.

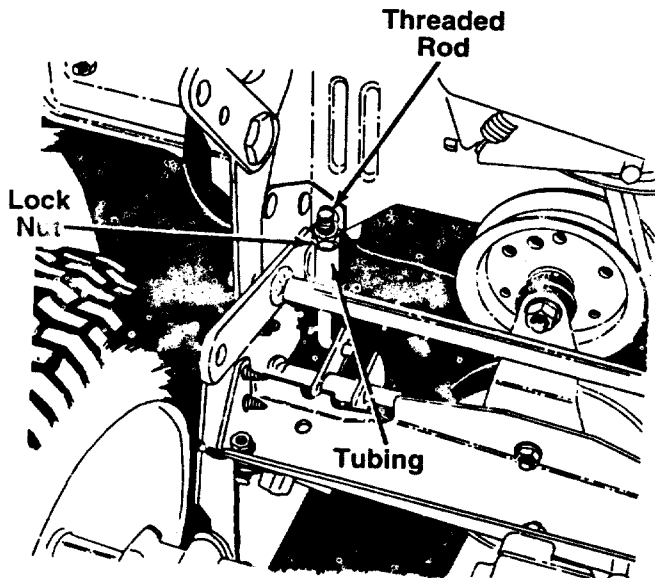

FIGURE 13.

Move the lock nut toward the tubing to start to disengage the deck earlier. Move the lock nut away from the tubing to obtain more drive in the cutting positions.



WARNING: Make certain the unit is adjusted so that the cutting blades are disengaged when the lift and disengagement lever is in the disengaged position.

WHEEL ADJUSTMENT

The caster (forward slant of the king pin) and the camber (tilt of the wheels out at the top) require no adjustment. Automotive steering principles have been used to determine the caster and camber on the tractor. The front wheels should toe-in 1/8 inch.

To adjust the toe-in, follow these steps.

1. Remove the hex nut and lock washer, and drop the tie rod end from the wheel bracket. See figure 14.
2. Loosen the hex jam nut on tie rod.
3. Adjust the tie rod assembly for correct toe-in. (See figure 14.) Retighten hex jam nut.

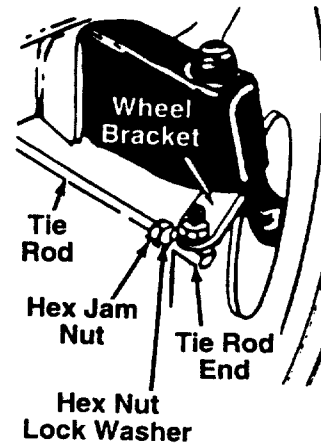

FIGURE 14.

Dimension "B" should be approximately 1/8" less than Dimension "A." See figure 15.

- A.) To increase Dimension "B," thread the rod into tie rod end.
- B.) To decrease Dimension "B," unscrew the tie rod from the tie rod end.
- C.) Reassemble tie rod. Check dimensions. Readjust if necessary.

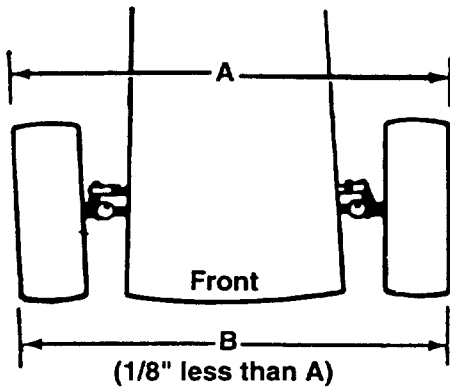

FIGURE 15.

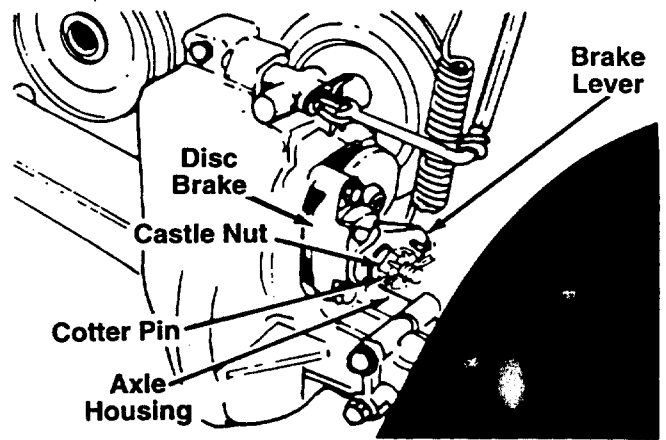

FIGURE 16.

CARBURETOR ADJUSTMENT



WARNING: If any adjustments are made to the engine while the engine is running (e.g. carburetor), disengage all clutches and blades. Keep clear of all moving parts. Be careful of heated surfaces and muffler.

Minor carburetor adjustment may be required to compensate for differences in fuel, temperature, altitude and load. To adjust the carburetor, refer to the separate engine manual packed with your unit.

NOTE: A dirty air cleaner will cause an engine to run rough. Be certain air cleaner is clean and attached to the carburetor before adjusting carburetor.

BRAKE ADJUSTMENT (See figure 16)

The brake is located by the left rear wheel inside the frame. During normal operation of this machine, the brake is subject to wear and will require periodic examination and adjustment.



WARNING: Do not have the engine running when you adjust the brake.

NOTE: Your brake may be equipped with a lock nut instead of the castle nut and cotter pin shown in figure 16.

To adjust the brake, remove the cotter pin from the castle nut (if so equipped). Adjust the nut so the brake starts to engage when the brake lever is 1/4" to 5/16" away from the axle housing.

NOTE: Figure 16 is shown with the unit tipped up on rear wheels for clarity only.

LUBRICATION



WARNING: Always stop engine and disconnect spark plug wire before cleaning, lubricating or doing any kind of work on lawn tractor.

STEERING GEARS

Lubricate teeth of steering gears with automotive multi-purpose grease after every 25 hours of operation or once a season.

STEERING SHAFT

Lubricate steering shaft at least once a season with light oil.

TRANSAXLE

The transaxle is lubricated and sealed at the factory and does not require checking. If disassembled for any reason, lubricate with 10 oz. of grease, part number 737-0148.

WHEELS

The front wheels are provided with grease fittings. The rear wheels must be removed from the axle for lubrication. Lubricate both front and rear wheels at least once a season with automotive multi-purpose grease.

PIVOT POINTS

Lubricate all pivot points with light oil at least once a season.

MAINTENANCE



WARNING: Disconnect the spark plug wire and ground against the engine before performing any repairs or maintenance.

TROUBLE SHOOTING

Refer to page 19 of this manual for trouble shooting information.

ENGINE

Refer to the separate engine manual for all engine maintenance instructions.

Maintain **engine oil** as instructed in the separate engine manual packed with your unit. Read and follow instructions carefully.

Service **air cleaner** every 10 hours under normal conditions. Clean every few hours under extremely dusty conditions. Poor engine performance and flooding usually indicates that the air cleaner should be serviced. To service the air cleaner, refer to the separate engine manual packed with your unit.

The **spark plug** should be cleaned and the gap reset once a season. Spark plug replacement is recommended at the start of each mowing season; check engine manual for correct plug type and gap specifications.

CUTTING BLADE

A. Removal for Sharpening or Replacement



WARNING: Be sure to disconnect and ground the spark plug wire and remove ignition key before working on the cutting blade to prevent accidental engine starting. Protect hands by using heavy gloves or a rag to grasp the cutting blades.

1. Remove the large bolt and lock washer which holds the blade and adapter to the blade spindle.
2. Remove the blade and adapter from the spindle.
3. If the blade or blade adapter needs replacing, remove the two small bolts, lock washers and nuts which hold the blade to the adapter.

B. Sharpening

Remove the cutting blade by following the directions of the preceding section.

When sharpening the blade, follow the original angle of grind as a guide. It is **extremely important** that each cutting edge receives an equal amount of grinding to prevent an unbalanced blade. An unbalanced blade will cause excessive vibration when rotating at high speeds, may cause damage to the mower and could break, causing personal injury.

The blade can be tested for balance by balancing it on a round shaft screwdriver. Remove metal from the heavy side until it balances evenly.

NOTE: It is recommended that the blade always be removed from the adapter for the best test of balance.

C. Reassembly

Before reassembling the blade and the blade adapter to the unit, lubricate the spindle and the inner surface of the blade adapter with light oil. Lubricating the bolt holes, bolts and inner surface of the nuts with light oil is also recommended. A 4 oz. plastic bottle of light oil lubricant is available. Order part number 737-0170. Engine oil may also be used.

When replacing the blade, be certain the wide blade is assembled on the right side of the deck. Be sure to install the blades with the side of the blades marked "Bottom" (or with part number) facing the ground when the mower is in the operating position.

Blade Mounting Torque

Center Bolt: 450 in. lbs. min., 600 in. lbs. max.

Blade Adapter Bolts: 200 in. lbs. min., 350 in. lbs. max.

To insure safe operation of your unit, ALL nuts and bolts must be checked periodically for correct tightness.

FUEL FILTER

Your unit is equipped with a replaceable in-line fuel filter. Replace filter whenever contamination or discoloration is noticed. Order replacement filter through your engine authorized servicer.

DRIVE BELT REMOVAL AND REPLACEMENT



WARNING: Disconnect the spark plug wire and ground it against the engine. Block the wheels of the unit.

NOTE: When changing the belts, a spring puller or other suitable tool is required to remove some of the springs. A spring puller (part number 732-0571) is available to assist in removal of springs.

Removing the Deck Belt

NOTE: Figures 17, 20 and 21 are shown with the unit tipped up for clarity. It is not necessary to tip the unit to remove the belts.

1. Place the lift lever in the disengaged position.
2. Remove the two hex bolts (belt keepers) from the engine pulley belt guard. See figure 17.

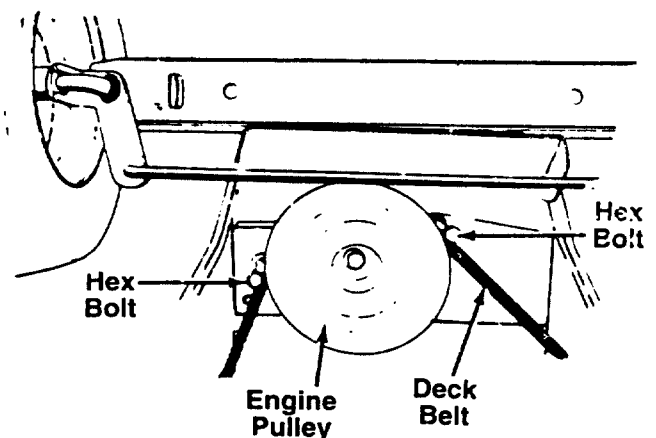

FIGURE 17.

NOTE: Make certain hex bolts are reassembled as shown in figure 17.

3. Unhook the deck belt from the engine pulley.
4. Place the lift lever in the engaged (all the way forward) position.
5. Disconnect the spring from the left rear transmission support bracket. See figure 18.
6. Disconnect the two front deck links by removing the hairpin clips and flat washers.

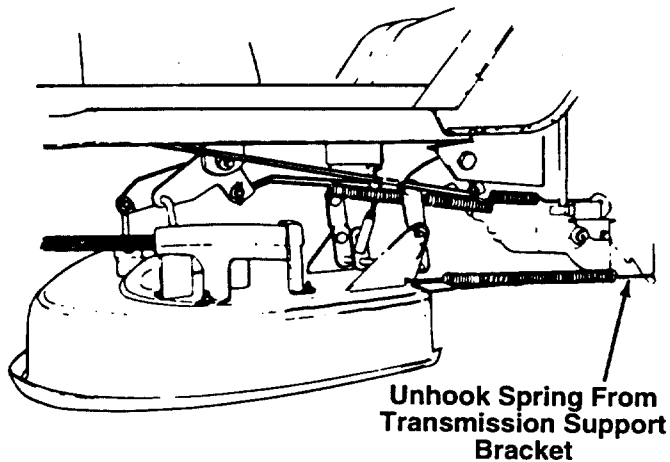

FIGURE 18.

7. Remove the belt guards at each deck pulley by removing the hex bolts, lock washers and hex nuts. See figure 19.
8. Remove and replace the belt, following the instructions in reverse order.

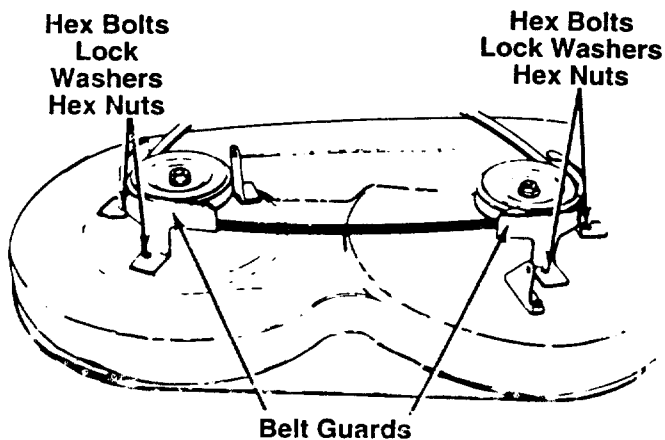

FIGURE 19.

Removing the Rear Drive Belt (Refer to figure 20)

1. Start the engine. Place shift lever in neutral. Place speed control lever in high speed position and turn engine off. Engage lift lever (move all the way forward). Do not set parking brake.

2. Disconnect the large spring from the transmission support bracket, using a spring puller or other suitable tool.

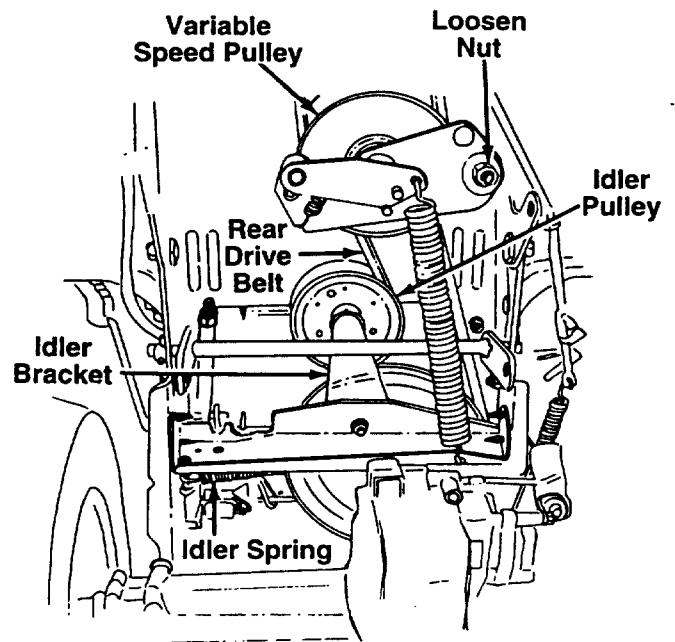

FIGURE 20.

3. Disconnect the idler spring from the bolt on the right side of the frame and transmission support bracket.
4. Loosen (**do not** remove) the hex nut which secures the variable speed pulley bracket to allow clearance in order to remove the belts. A 9/16" socket wrench is required.
5. Remove belt from transmission pulley and idler pulley. Remove the rear drive belt from around the top of the variable speed pulley.
6. Reassemble new belt, following instructions in reverse order.

Removing the Forward Drive Belt (See figure 21)

1. To remove the forward drive belt, first remove the rear drive belt (steps 1 through 5 of the preceding instructions).
2. Remove the deck belt from the engine pulley (steps 1 through 3 of "Removing the Deck Belt").
3. Remove the engine pulley belt guard by removing two self-tapping screws from each side of the frame. Remove the engine pulley belt guard by moving it back and to the left.
4. Remove the forward drive belt from the engine pulley and from the variable speed pulley.
5. Reassemble new belt, following instructions in reverse order.

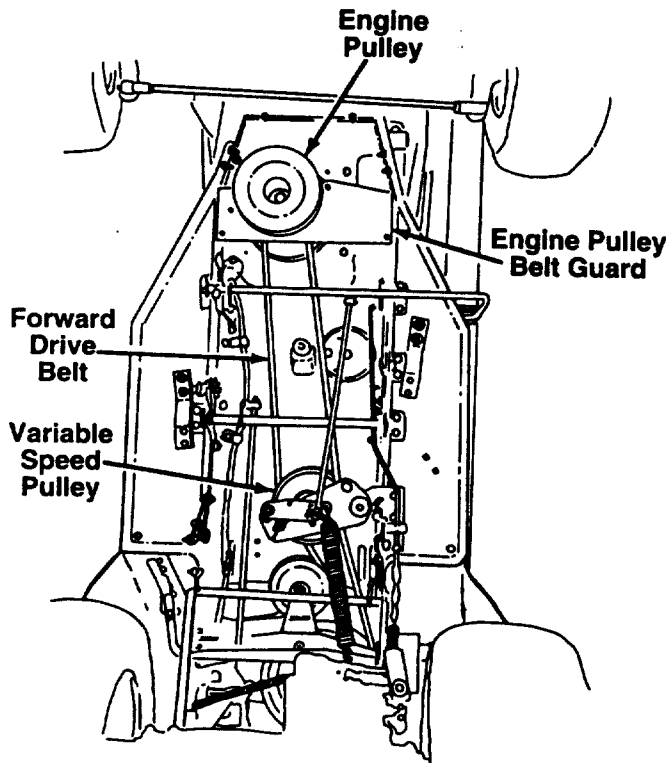

FIGURE 21.

BATTERY REMOVAL OR INSTALLATION



WARNING: When removing the battery, follow this order of disassembly to prevent the screwdriver from shorting against the frame.

1. Remove the Negative cable.
2. Remove the Positive cable.

To install a battery:

1. Attach the Positive cable.
2. Attach the Negative cable.

JUMP STARTING

1. Attach the first jumper cable from the Positive terminal of the good battery to the Positive terminal of the dead battery.
2. Attach the second jumper cable from the Negative terminal of the good battery to the **FRAME OF THE UNIT WITH THE DEAD BATTERY.**



WARNING: Failure to use this starting procedure could cause sparking, and the gas in either battery could explode.

BATTERY MAINTENANCE

1. Check periodically (every two weeks or before and after charging) to be sure electrolyte level is above the lowest line on battery. Add only distilled water or a good quality drinking water. **NEVER** add additional acid or other chemicals to battery after initial activation.
2. The battery should be checked with a hydrometer after every 25 hours of operation. If the specific gravity is less than 1.225, remove battery and recharge.
3. Coat the terminals and exposed wiring with a thin coat of grease or petroleum jelly for longer service and protection against electrolyte corrosion.
4. The battery should be kept clean. Any deposits of acid should be neutralized with soda and water. Be careful not to get this solution in the cells.

BATTERY STORAGE

1. Charge battery using normal methods. **NEVER** store discharged battery as it will not recover.
2. When storing battery for extended periods, disconnect battery cables. Removing battery from unit is recommended.
3. Store in cold, dry place.
4. Recharge battery whenever the specific gravity is less than 1.225, before returning to service, or every two months, whichever occurs first.

COMMON CAUSES FOR BATTERY FAILURE ARE:

1. Overcharging
2. Undercharging
3. Lack of water
4. Loose hold downs and/or corroded connections
5. Excessive loads
6. Battery electrolyte substitutes
7. Freezing of electrolyte

NOTE: THESE FAILURES DO NOT CONSTITUTE WARRANTY.

TIRES

Recommended operating tire pressure is approximately 12 p.s.i. (check sidewall of tire for tire manufacturer's recommended pressure). Maximum tire pressure under any circumstances is 30 p.s.i. Equal tire pressure should be maintained on all tires.

When installing a tire to the rim, be certain rim is clean and free of rust. Lubricate both the tire and rim generously. Never inflate to over 30 p.s.i. to seat beads.



WARNING: Excessive pressure (over 30 p.s.i.) when seating beads may cause tire/rim assembly to burst with force sufficient to cause serious injury.

OFF-SEASON STORAGE

If the machine is to be inoperative for a period longer than 30 days, prepare for storage as follows.

1. Clean the engine and the entire unit thoroughly.
2. Lubricate all lubrication points. Wipe the entire machine with an oiled rag to protect the surfaces.
3. Refer to the separate engine manual for correct engine storage instructions.

4. Refer to battery storage instructions on page 17.
5. Store unit in a clean, dry area. Do not store next to corrosive materials, such as fertilizer.

NOTE: *When storing any type of power equipment in an unventilated or metal storage shed, care should be taken to rustproof the equipment. Using a light oil or silicone, coat the equipment, especially any chains, springs, bearings and cables.*

GRASS COLLECTOR AVAILABLE

Grass collector stock no. 80-35106, factory no. 190-064, is available as optional equipment for the lawn tractor shown in this manual.



WARNING: The mower should not be operated without the entire grass catcher or chute deflector in place.

NOTE: *Under normal usage bag material is subject to wear, and should be checked periodically. Be sure any replacement bag complies with the mower manufacturer's recommendations. For replacement bags, use only factory authorized replacement bag.*

TROUBLE SHOOTING GUIDE

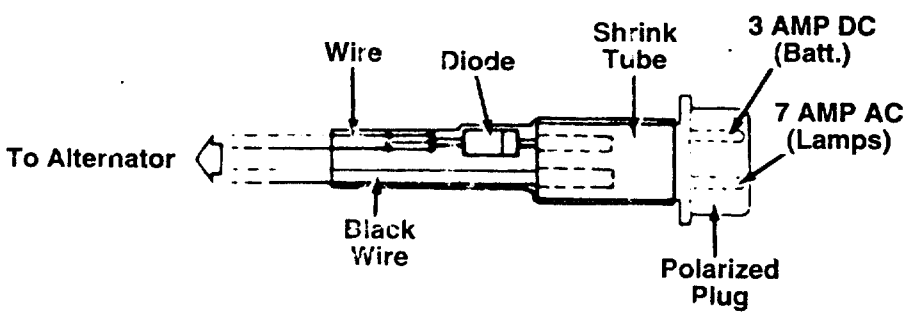
TROUBLE	LOOK FOR	REMEDY
Engine will not crank	Battery installed incorrectly	The battery must be installed with the negative terminal, identified at the terminal post by (Neg, N or -), grounded. The positive terminal (Pos, P or +) attaches to the large cable from the solenoid. The small red wire from the fuse holder or circuit breaker is also attached to the positive terminal.
	Blown fuse or circuit breaker	Replace fuse with 7-1/2 amp. automotive type fuse. Fuses seldom fail without a reason. The problem must be corrected. Check for loose connections in the fuse holder. Replace fuse holder if necessary. A dead short may be in the cranking or charging circuit where the insulation may have rubbed through and exposed the bare wire. Replace the wire or repair with electrician's tape if the wire strands have not been damaged. Note: Look for a wire pinched between body panels, burned by the exhaust pipe or muffler or rubbed against a moving part.
	Battery is dead or weak	Use a hydrometer to check the condition of the battery. The Specific Gravity (s.g.) should be 1.265 at 80°F. (1.215 s.g. minimum needed for cranking engine). The reason for the battery failing must be determined. (1) Defective battery. Battery will not accept or hold a full charge. (2) Short circuit. Check for grounded wire. (3) Charging system not working. The charging system is an alternator located under the flywheel. It is unregulated and rated 3 amp. at 3600 r.p.m. A diode (rectifier) is located in the output lead just before the wire harness plug on the engine side.  <p>The diode changes A.C. to D.C. to charge the battery. A bad diode can either fail to charge the battery or discharge the battery if the alternator is shorted as well as the diode. To test: (1) Disconnect charger lead from the battery (small red wire). (2) Connect 12 V small test lamp between the 3 amp. D.C. charge lead and the positive terminal of the battery. (3) With the engine off, the lamp should not light. If it does, the diode and possibly the alternator should be replaced. (4) Start the engine. The lamp should light. If it does not, the alternator (stator) or lead wire is bad and should be replaced.</p>
	Mechanical failure (Wires and switches)	The interlock system includes two mechanical activated switches which are wired in series in the circuit used to energize the starter solenoid. While testing the interlock system, you will make the mower temporarily unsafe by permitting the engine to be started with the blade and clutch engaged. WARNING: While testing, disengage the clutch, shut off the blade control, set the parking brake and place the gear shift lever in neutral. Attach a wire (minimum 18 gauge) to the positive terminal of the battery and touch the other end to the small terminal on the solenoid. If the engine does not crank: (1) There is a loose connection or poor ground. (2) The solenoid may be bad. The solenoid can be checked by using a heavy wire (#8 gauge minimum) and jumping between the two large terminals. If the engine cranks, the solenoid is bad. (3) If the engine does not crank when you jump the solenoid, have the starter motor tested by an authorized engine dealer. If the engine does crank, the problem is with one of the safety switches, ignition switch or the wire between the fuse holder (or circuit breaker) and the small terminal on the solenoid. Note: Look for a poor connection at the switches or a defective switch. Replace if necessary.
Engine cranks but will not start	Throttle or choke not in starting position	Check owner's guide for correct position for throttle control and choke for starting.
	No spark to spark plug	Spark plug lead disconnected. Connect lead. Hold spark plug lead away from engine block about 1/8". Crank engine. There should be a spark. If not, have engine repaired at authorized engine service dealer. Faulty spark plug. To test, remove spark plug. Attach spark plug lead to spark plug. Ground the spark plug body against the engine block. Crank the engine. The spark plug should fire at the electrode. Replace if it does not.

TROUBLE SHOOTING GUIDE (Continued)

TROUBLE	LOOK FOR	REMEDY
	No fuel to the carburetor	Gasoline tank empty. Fill. Fuel line or in-line fuel filter plugged. Remove and clean fuel line. Replace filter if necessary.
	Air filter dirty	If the air cleaner is dirty, the engine may not start. Clean or replace as recommended by the engine manufacturer.
Engine smokes	Engine loses crankcase vacuum	Dipstick not seated or broken. Replace defective part. Engine breather defective. Replace.
Excessive vibration	Bent or damaged blade spindle	Stop engine immediately. Check all pulleys, blade adapters, keys and bolts for tightness and damage. Tighten or replace any damaged parts.
	Bent blade	Stop engine immediately. Replace damaged blade. Only use original equipment blades.
Mower will not discharge grass or leaves uncut strips	Engine speed low Transmission selection Blades short or dull	Throttle must be set at full throttle. Use lower transmission speed. The slower your ground speed, the better the quality of cut. Sharpen or replace blades (uncut strip problem only).

TMO-3394704

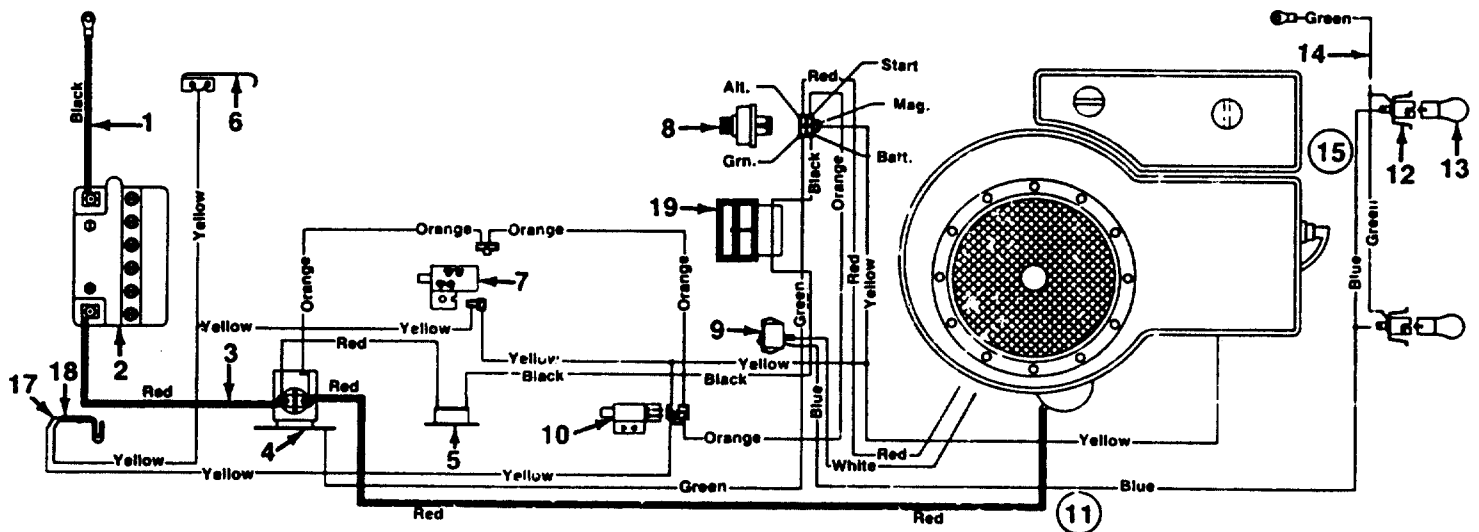

PARTS LIST FOR ELECTRICAL SYSTEM

REF. NO.	PART NO.	DESCRIPTION	REF. NO.	PART NO.	DESCRIPTION
1	725-0976A	Ground Wire	11	629-0031	Harness
2	725-0514A	Battery	12	725-1651	Socket
3	725-0926	Electric Wire	13	725-0963	Bulb
4	725-1426	Solenoid	14	725-0916A	Ground Wire
5	725-0459	Circuit Breaker	15	629-0086	Headlight Harness
6	732-0758	Spring Switch (Reverse)	16	725-0222	Headlight (Round—Not Shown)
7	725-0819A	Safety Switch (Deck)	17	725-1303	Safety Switch (Seat)
8	725-0267	Ignition Switch	18	725-1439	Safety Switch (Seat)
9	725-0634	Light Switch	19	725-0925	Ammeter
10	725-3169A	Safety Switch (Clutch)			

TMO-3394704

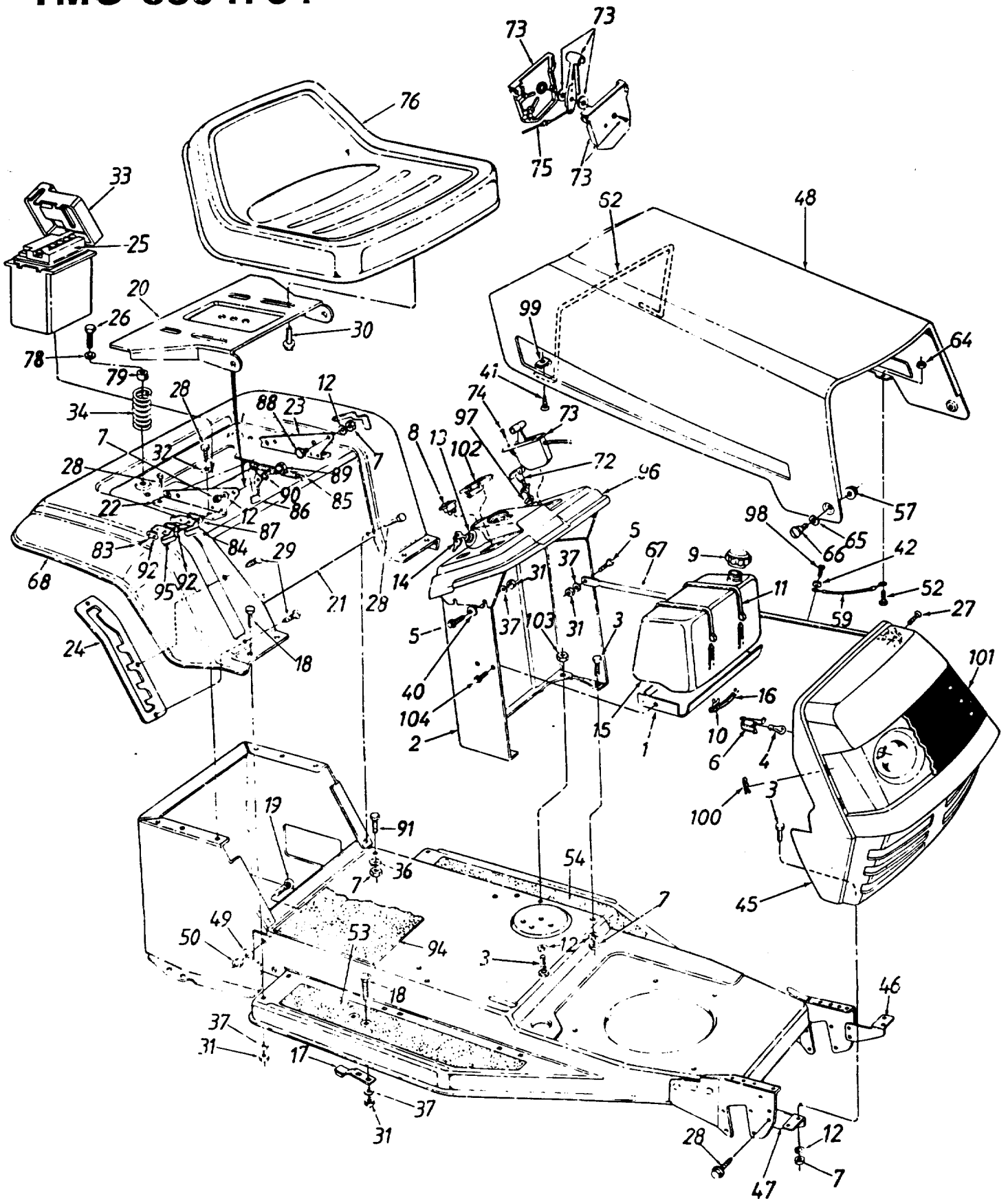

TMO-3394704

11.5 H.P. 38" LAWN TRACTOR PARTS LIST FOR MODEL TMO-3394704

REF. NO.	PART NO.	DESCRIPTION	REF. NO.	PART NO.	DESCRIPTION
1	17932	Gas Tank Support Brkt.	49	736-0217	L-Wash. 3/8" I.D.—H.D.
2	17933	Pedestal	50	712-0241	Hex L Nut 3/8-24 Thd.
3	710-0118	Hex Bolt 5/16 18 x .75" Lg.*	52	710-0473	Truss Mach. Scr. #10-24 x .5" Lg.
4	725-0963	Bulb			Foot Pad—R.H.
5	710-0258	Hex Bolt 1/4 x .62" Lg.	53	723-0308B	Foot Pad—L.H.
6	725-1651	Socket	54	723-0309B	Lock Nut 1/4-28 Thd.
7	712-0267	Hex Nut 5/16-18 Thd.*	57	712-0380	Hood Stop
8	725-0634	Light Switch	59	723-0302	Hood Spring
9	751-3071	Gas Cap	62	732-0699	Hex Sems Nut #10-24 Thd.
10	726-0205	Hose Clamp	64	712-0272	Spr. V/ash. .39" I.D. x .62" O.D.
11	726-0209	Cable Tie	65	736-0413	Shld. Bolt
12	736-0119	L-Wash. 5/16" I.D.*	66	738-0724	Grille Support
13	725-0267	Ignition Switch	67	749-0722B	Trim Strip 81" Lg.
14	725-0201	Ignition Key	68	731-0511-81	Choke Control
15	751-0553	Fuel Tank	72	746-0616A	Throttle Control Box
16	751-0535-15	Gas Line 15" Long	73	831-0823A	Truss AB-Tap Scr. #10 x .5"
17	761-0194	Blade Brake Ass'y.	74	710-0779A	Throttle Wire
18	710-0134	Carriage Bolt 1/4-20 x .62"	75	746-0501	Seat Assembly
19	710-0793	Ribbed Neck Bolt 3/8-24 x .8"	76	757-0345	Fl-Wash. .344" I.D. x .88" O.D.
20	15607D	Seat Pivot Brkt.	78	736-0159	Bushing
21	17590	Rear Fender	79	722-0160	Hex Tap Scr. #8 x .5" Lg.
22	17704	Seat Hinge Support Brkt.—R.H.	83	710-0227	Safety Switch (Seat)
23	17703	Seat Hinge Support Brkt.—L.H.	84	725-1439	Ext. Spring 5.31" Lg.
24	17553	Deck Lift Index Brkt.	85	732-0581B	Seat Lift Brkt.
25	725-0514A	Battery	86	17239A	Insulator Boss Plate
26	710-0817	Hex Self-Tap Screw 5/6-18 x 1.25" Lg.	87	726-0278	Shld. Bolt .437" Dia. x .162" Lg.
27	710-0255	Truss Mach. Scr. 1/4-20 x .75" Lg.	88	738-0155	Shld. Bolt .437" Dia. x .268" Lg.
28	710-0726	Hex AB-Tap Scr. 5/16 x .75" Lg.	89	738-0296	Spr. Wash. .445" I.D. x .75" O.D.
29	710-1017	Torx Mach. AB-Tap Scr. 1/4 x .62" Lg.	90	736-0141	Hex Wash. Hd. Scr. 5/16-18 x .62" Lg.
30	710-0623	Hex Self-Tap Scr. 3/8-16 x .75" Lg.	91	710-0604	Insulator Plate
31	712-0287	Hex Nut 1/4-20 Thd.*	92	726-0279	Center Foot Pad
32	736-0607	External L-Wash. 5/16" I.D.	94	723-0423	Safety Switch (Seat)
33	731-0871A	Battery Box w/Cover	95	725-1303	Dash Panel
34	732-0588	Compression Spring	96	731-1228	Retainer Clip
36	736-0242	Bell-Wash. 5/16" I.D.	97	17782	Truss Mach. B-Tap Scr. #10 x .5" Lg.
37	736-0329	L-Wash. 1/4" I.D.*	98	710-0351	Speed Nut
40	736-0270	Bell-Wash. .265" I.D. x .75"	99	726-0130	Internal Cotter Pin 5/16" Dia.
41	710-3009	Pan Hd. Scr. 10-24 x .75" Lg.	100	714-0104	Lens
42	736-0400	Fl-Wash. .218" I.D. x .62"	101	731-1099A	Ammeter
45	17931A	Grille	102	725-0925	Hex Jam Nut 5/16-18 Thd.
46	17595	Grille Mtg. Brkt.—L.H.	103	712-3007	Hex Wash. Hd. Tap Scr. 1/4-20 x .5" Lg.
47	17596	Grille Mtg. Brkt.—R.H.	104	710-0599	
48	17941	Hood			

*Common Hardware—May be purchased locally.
IMPORTANT: DO NOT order parts by reference number (Ref. No.)

NOTE: Specifications subject to change without notice or obligation.

TMO-3394704

11.5 H.P. 38" LAWN TRACTOR PARTS LIST FOR MODEL TMO-3394704

REF. NO.	PART NO.	DESCRIPTION	REF. NO.	PART NO.	DESCRIPTION
1	17584	Front Axle Ass'y.—R.H.	29	750-0532	Spacer .985" I.D.
2	17585	Front Axle Ass'y.—L.H.	30	750-0535	Spacer .380" I.D.
3	16481	Steering Arm	31	17548	Front Pivot Bar Support Brkt.
4	710-0152	Hex Bolt 3/8-24 x 1" Lg.*	32	17547	Rear Pivot Bar Support Brkt.
5	710-0538	Hex Bolt 5/16 18 x .62" (Spec.)	33	683-0002	Pivot Bar Ass'y.
6	710-0772	Hex Bolt 5/16-24 x 2" Lg.*	35	734-0863	Front Wheel Ass'y. Comp.**
7	723-3018	Ball Joint 3/8-24 Thd.		734-0864	Tire Only**
8	711-0838	Steering Drag Link		734-C997A	Rim Only
9	712-0237	Hex L-Nut 5/16-24 Thd.	37	737-0280	Grease Fitting
10	712-0241	Hex Nut 3/8-24 Thd.	38	734-C255	Air Valve
11	712-0267	Hex Nut 5/16-18 Thd.*	42	741-0487A	Bearing
12	712-0446	Hex Jam Nut, 3/8-24 Thd.	43	712-0237	Hex L-Nut 5/16-24 Thd.
13	714-0470	Cotter Pin 1/8 Dia.	44	741-0501	Steering Column Brg.
14	717-0622A	Steering Gear Segment	45	710-0837	Cr-Sunk Scr. #10 x 5/8" Lg.
15	723-3018	Drag Link Ball Joint 3/8-24 Thd.	46	731-0805	Steering Wheel
16	726-0214	Push Cap	47	731-0220	Steering Wheel Cap
17	736-0119	L-Wash. 5/16" I.D.*	48	731-0484A	Hub Cap
18	736-0169	L-Wash. 3/8" I.D.*	49	731-0559	Bellow/ Steering Column
19	736-0187	FI-Wash. .64" I.D. x 1.24"	50	736-0242	Bell-Wash. .345" I.D. x .88"
20	736-0343	FI-Wash. .340" I.D. x 1.125"	51	712-0798	Hex Nut 3/8-16 Thd.*
22	736-0271	Spr. Wash. .62" I.D. x .62"	52	738-0527	Shld. Bolt 1/2" Dia. x 2.04"
23	736-0285	FI-Wash. .635" I.D. x 1.585"	54	736-0356	Bell-Wash. .39" x 1.38" O.D.
24	17198	Retainer Plate	55	731-1134	Plastic Tube
25	738-0141	Shld. Bolt .437" Dia. x .350"	56	17545	Pivot Bar Side Plate—L.H.
26	738-0730	Steering Shaft	58	17546	Pivot Bar Side Plate—R.H.
27	741-0487A	Hex Flange Brg. .632" I.D.	59	710-0604	Hex Wash. Tap Scr. 5/16-18 x .62" Lg.
28	747-0753	Tie Rod 20" Lg.	61	736-0217	L-Wash. 3/8" I.D. (H.D.)
				741-0225	Hex Flange Brg. .634" Dia.

*Common Hardware—May be purchased locally.
IMPORTANT: DO NOT order parts by reference
number (Ref. No.).

**Note: If brand of tire is important, order by part number and
description (description is printed on the sidewall of tire) [i.e.
Armstrong Super Turf, Goodyear Softrac, Carlisle Turf Saver, etc.].

Part No.	Description
788-0638	Red Spray Paint
777-5268	Steering Cap Label
777-0490	Labels—Side of Hood
777-0491	"Montgomery Ward" Logo— Rear Fender
770-8085G	Operating Manual

**11.5 H.P. 38" LAWN TRACTOR
PARTS LIST FOR MODEL TMO-3394704**

REF. NO.	PART NO.	DESCRIPTION	REF. NO.	PART NO.	DESCRIPTION
1	16670	Engine Pulley Belt Guard Ass'y.	72	736-0222	External L-Wash. 1/4" I.D.
2	710-0776A	Hex AB-Tap Scr. 1/4 x .62"	73	710-0176	Hex Bolt 5/16-18 x 2.75" Lg.*
3	710-0833	Hex Bolt 5/16-18 x 5-1/4" Lg.	74	710-0351	Truss Mach. B-Tap Scr. #10 x .50" Lg.
4	712-0267	Hex Nut 5/16-18 Thd.*			Foot Pedal Rod Ass'y.
5	736-0242	Bell-Wash. .345" I.D. x .88	75	17644A	Foot Pad
6	710-0286	Truss-Mach. Scr. 1/4-20 x .50**	76	735-0239	Ribbed Neck Bolt 5/16-24 x .84"
7	710-1223	Hex Bolt 1/4-20 x 3.5" Lg.	77	710-1012	Ferrule
8	736-0270	Bell-Wash. .265" I.D. x .75	80	711-0198	Hex Sems Nut 1/4-20 Thd.
10	749-0836	Speed Selector Brace	81	712-0271	Cot-Pin 1/8" Dia. x 1.25" Lg.
11	712-0138	Hex Nut 1/4-20 Thd.*	82	714-0470	Cot-Pin 3/32" Dia. x .75" Lg.
12	17128A	Spring Retainer Brkt.	83	714-0507	Sq. Key 1/4 x 2.0" Lg.
15	15891C	Idler Bracket	85	714-0114	FI-Wash. .635" I.D. x 1.0"
16	16554A	Var. Speed Torque Brkt. Ass'y.	86	736-0256	Brake Rod
17	16676A	Variable Speed Brkt. Ass'y.	88	747-0593	Spacer 5/8" I.D. x 1.2" Lg.
18	17962	Switch Plate	89	750-0800	Ground Wire 7.25" Lg.
19	710-0118	Hex Bolt 5/16-18 x .75" Lg.*	90	725-0976A	Speed Selector Lever
20	710-0151	Hex Bolt 3/8-24 x 2.0" Lg. Gr. 5	91	17457A	5-Speed Selector Brkt.
22	710-0757	Hex Bolt 7/16-20 x 1.5" Lg.*	92	16693A	Shld. Bolt .437" Dia. x .47" Lg.
24	711-0768	Belt Guard Pin	93	738-0138	Ferrule
25	712-0241	Hex Nut 3/8-24 Thd.*	94	711-0677	Hex Bolt 1/4-28 x 1.25" Lg.
27	712-0287	Hex Nut 1/4-20 Thd.*	95	710-0428	Intern. Cot-Pin 5/16" Dia.
29	712-3035	Hex Jam Nut 9/16-18 Thd.	96	714-0104	Spacer .375" I.D. x .625"
30	710-0902	Hex Bolt 3/8-24 x 3.75" Lg.	97	750-0703	FI-Wash. .344" I.D. x .62"
31	716-0114	Snap Ring	99	736-0264	FI-Wash. .25" I.D. x .62" O.D.
32	717-0800	Variable Speed Pulley Ass'y.	100	736-0463	Speed Control Rod
34	736-0607	Ext. L-Wash. 5/16" I.D.	101	747-0675A	FI-Wash. 3/8" I.D. x 1.25" O.D.
35	736-0258	FI-Wash. 3/8" I.D. x 1.0" O.D.	102	736-0133	Cot-Pin 1/8" Dia. x 1.0" Lg.
36	732-0384	Extension Spring 6.12" Lg.	103	714-0115	FI-Wash. .34" I.D. x .68"
37	732-0556	Extension Spring 7.58" Lg.	104	736-0275	FI-Wash. .34" I.D.
38	732-0568	Extension Spring 2.59" Lg.	105	736-0278	Hex L-Bolt 5/16-24 x .75" Lg.
39	736-0117	FI-Wash. .385" I.D. x .620"	106	710-0627	Rear Wheel Ass'y. Comp.
40	736-0119	L-Wash. 5/16" I.D.*	107	734-0817	Tire Only
41	736-0169	L-Wash. 3/8" I.D.*	108	734-0418	Rear Wheel Rim Ass'y. Only
42	736-0171	L-Wash. 7/16" I.D.*	109	734-0603A	Bell-Wash. .345" I.D. x .88"
43	736-0322	FI-Wash. .450" I.D. x 1.25"	110	736-0242	Hex Jam Nut 1/4-20 Thd.
44	736-0329	L-Wash. 1/4" I.D.*	113	712-0298	Shift Lever Adjusting Link
45	736-0331	Bell-Wash. .39" I.D. x 1.13"	114	17178A	Shift Lever Spring Brkt.
46	736-0355	FI-Wash. .56" I.D. x 1.0" O.D.	115	16482	Brake Rod Guide Brkt.
47	736-0414	Washer "Teflon" .565 I.D.	116	17507	Hex Bolt 1/4-20 x .50 Lg.*
48	736-0427	Bell-Wash. 9/16" I.D. x 1.125"	117	710-0289	Hex Wash. Hd. Tap Scr. 1/4-20 x .5" Lg.
49	738-0569	Shaft .56" Dia. x 3.875" Lg.	118	710-0599	Intern. Cotter Pin
50	741-0405	Thrust Brg. 1.25 O.D.			Safety Switch (Clutch)
51	741-0419	Flanged Nylon Brg.	119	714-0149B	Knob
52	741-0495	Nylon Flanged Brg.	120	725-3169A	Retaining Ring
53	747-0599A	Speed Control Rod	121	720-0232	Compression Spring 1.5" Lg.
54	750-0703	Spacer	122	726-0231	Hex Tap Scr. 5/16-18 x .62"
55	754-0280	V-Belt	123	732-0499	FI-Wash. .469" I.D. x .88"
56	754-0281	V-Belt	124	710-0604	Shift Rod Ass'y
57	656-0003	V-Pulley 3" Dia.	125	736-0226	Shift Rod
58	756-0437	Idler Pulley 3-1/8" Dia.	126	747-0694A	Shift Lever Support
59	756-0551	Dbl. Pulley 6.0" Dia. x 3.56"	127	747-0685	Hex Wash. Hd. #8 x .50" Lg.
60	732-0303	Extension Spring 3.18" Lg.	130	17179	Insulator Nut Plate
61	732-0413	Extension Spring 7.08" Lg.	131	710-0227	Spring Switch
62	748-0234	Shld. Spacer .500" Dia.	132	726-0222	Hex Tap Scr. 3/8-16 x 1.25"
63	734-0255	Air Valve	133	725-0758	Hex Bolt 5/16-24 x 1.25" (Gr. 5)
64	17588A	Front Frame	134	710-0502A	Hex Nut 5/16-24 Thd.*
65	17589	Rear Frame	135	710-0672	Engine, B&S 259707-0146-01
66	16654	Transaxle Support Brkt.	137	712-0123	Wave Wash. .445" I.D.
67	16659	Transaxle Brkt. Reinforcement	138	11.5 H.P.	Needle Brg. (2 Req'd.)
68	710-0726	Hex Wash. AB-Tap Scr. 5/16 x .75" Lg.	141	736-C141	5-Speed Indicator Strip
69	710-0258	Hex Bolt 1/4-20 x .62" Lg.*	143	741-0404	Ext. Spring 2.04" Lg.
70	725-1426	Solenoid	144	777-0404	
71	725-0459	Circuit Breaker	145	732-0691	

TMO-3394704

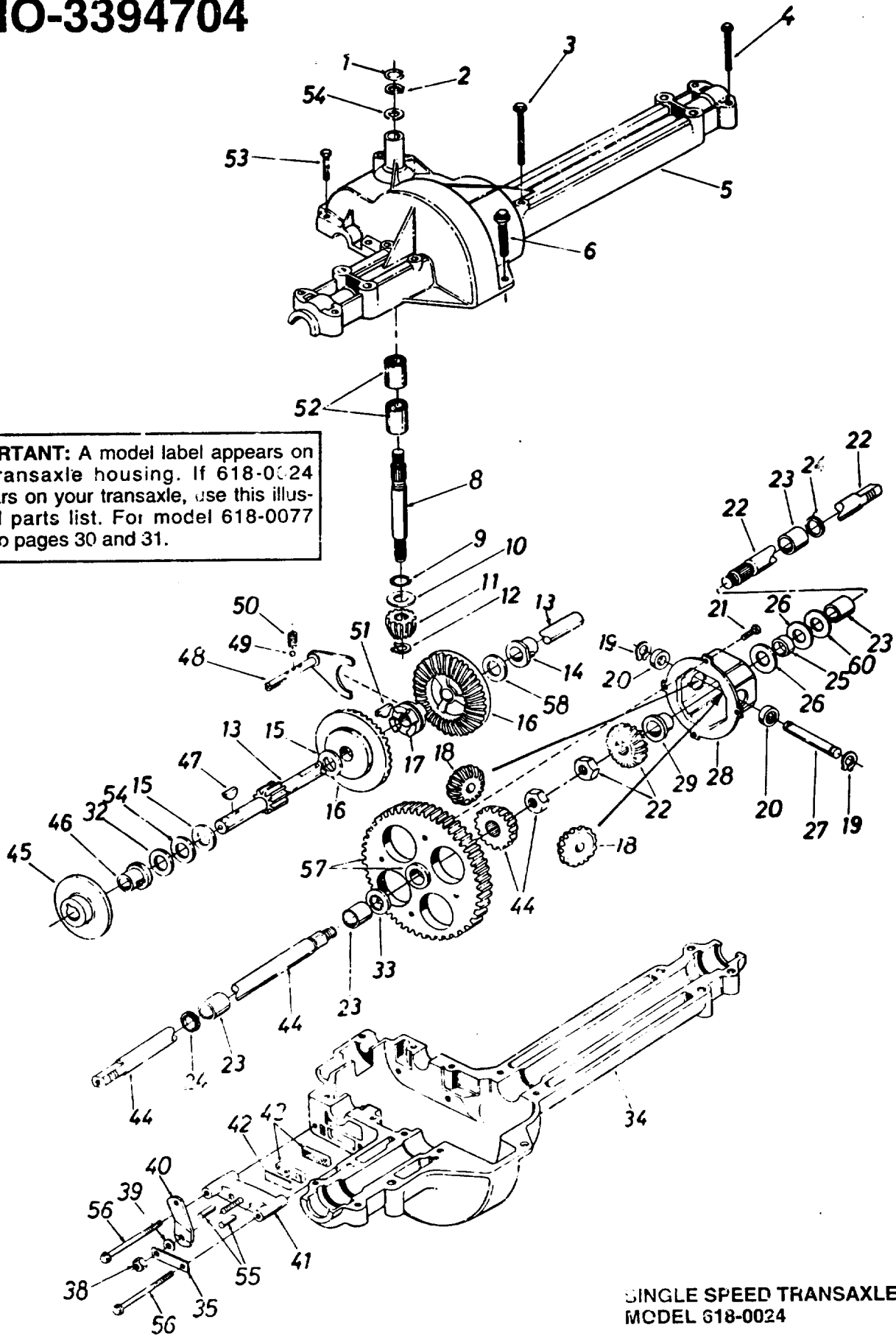

IMPORTANT: A model label appears on the transaxle housing. If 618-0024 appears on your transaxle, use this illustrated parts list. For model 618-0077 refer to pages 30 and 31.

SINGLE SPEED TRANSAXLE—L.H.
MODEL 618-0024

TMO-3394704

PARTS LIST FOR SINGLE SPEED TRANSAXLE LEFT HAND 618-0024

REF. NO.	PART NO.	DESCRIPTION	REF. NO.	PART NO.	DESCRIPTION
1	732-0614	Wire Ring	34	719-0303	Lower Housing
2	716-0108	Retaining—Ring	35	718-0150	Anti-Rotation Brkt.
3	710-0854	Hex Bolt 1/4-20 x 1.75" Lg.*	38	712-0273	Hex Nut 5/16-24 Thd.
4	710-0809	Hex Tap Scr. 1/4-20 x 1.25" Lg.	39	736-0371	Fl-Wash. .344" I.D. x .875" O.D.
5	717-0764A	Upper Housing	40	717-0772A	Actuating Arm
6	710-0642	Hex TT-Tap Scr. 1/4-20 x .75" Lg.	41	761-0198	Brake Yoke
8	711-0861	Input Shaft	42	717-0682	Puck Plate
9	721-0178	Square Seal 5/8" I.D.	43	717-0678	Brake Puck
10	736-0335	Thrust Washer 5/8" I.D. x 1.25" O.D.	44	717-1022	Axle L.H. Ass'y.
11	717-0633	Pinion Input 14T	45	717-0677	Brake Disc
12	716-0171	Retaining Ring	46	741-0337	Flange Bearing 5/8" I.D. x 15/16" Lg.
13	717-0768	Drive Shaft	47	714-0161	Woodruff Key 3/16 x 5/8 HT
14	741-0336	Flange Brg. 5/8" I.D. x 3/4" Lg.*	48	717-0754	Shift Fork Ass'y.
15	736-0335	Fl-Wash. 5/8" I.D. x 1.25"	49	741-0862	Ball Detent .250" Dia.
16	717-0757	Bevel Gear 42T	50	732-0663	Spring Detent
17	717-0667	Clutch Collar	51	714-0169	#9 Hi-Pro Key-3/16" x 3/4" Dia. HT
18	717-1020	Miter Gear 15T (H.D.)	52	741-0335	Needle Brg. 5/8" I.D. x 1/2" Lg.
19	716-0184	Snap Ring	53	710-0855	Hex Bolt 1/4-20 x 1.00" Lg.
20	741-0589	Thrust Bearing	54	736-0349	Fl-Wash. 5/8" I.D. x 1" O.D. x .020 Thk.
21	710-0862A	Pan Head Scr. 1/4-20 x .50" Lg. w/Patch	55	741-0343	Actuating Pin 5/16" Dia.
22	717-1023	Axle R.H. Ass'y.	56	710-1206	Hex Wash Hd. Self-Tap Scr. 1/4-20 Thd.
23	741-0340	Sleeve Bearing 3/4" I.D. x 1.0" Lg.	57	717-0767	Differential Gear 72T Ass'y. w/Bearing
24	721-0179	Oil Seal 3/4" I.D.	58	736-0349	Fl-Wash. 5/3" I.D. x 1" O.D. x .020 Thk.
25	750-0827	Axle Spacer		736-0495	Thrust Wash. 5/8" I.D. x 1" O.D. x .025" Thk.
26	736-0445	Fl-Wash. .760" I.D. x 1.5" O.D.	60	**	Washer (See Below)
27	711-0918	Cross Shaft	—	737-0148	Grease—Shell (10 oz.)
28	717-1252	Differential Can Ass'y.			
29	—	Part of Ref. 28			
32	**	Washer (See Below)			
33	736-0445	Fl-Wash. .760" I.D. x 1.5" O.D.			

**Ref. No. 32 736-0495 Thrust Wash. 5/8" I.D. x 1" O.D. x .025" Thk.
736-0336 Fl-Wash. 5/8" I.D. x 1" O.D. x .030" Thk.
736-0494 Thrust Wash. 5/8" I.D. x 1" O.D. x .035" Thk.
736-0337 Fl-Wash. 5/8" I.D. x 1" O.D. x .040" Thk.

**Ref. No. 60 736-0492 Fl-Wash. .76" I.D. x 1.5" O.D. x .010" Thk.
736-0493 Fl-Wash. .76" I.D. x 1.5" O.D. x .020" Thk.
736-0351 Fl-Wash. .76" I.D. x 1.5" O.D. x .030" Thk.
736-0445 Fl-Wash. .76" I.D. x 1.5" O.D. x .050" Thk.

TMO-3394704

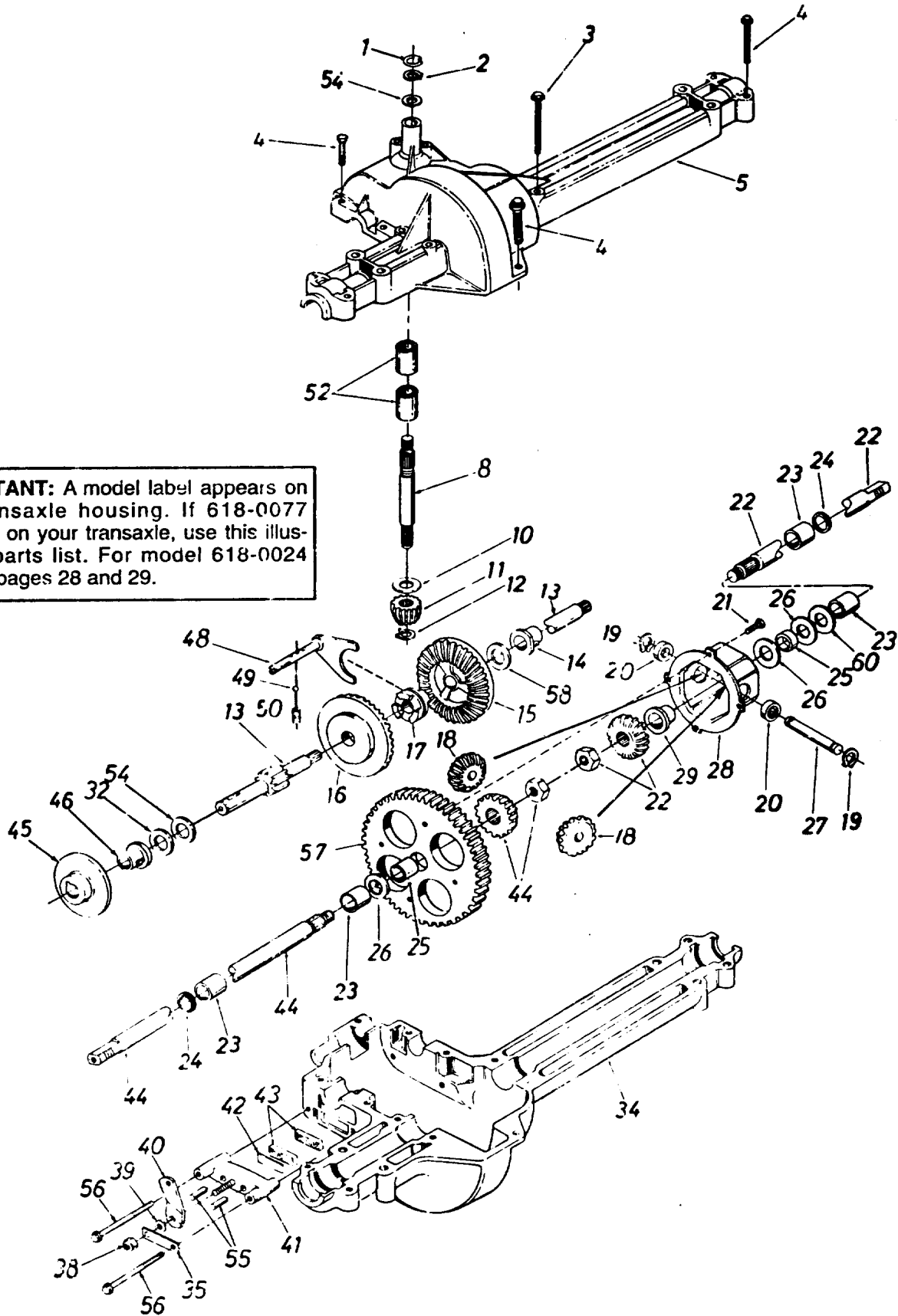

TMO-3394704

PARTS LIST FOR SINGLE SPEED TRANS.AXLE LEFT HAND 619-0077

REF. NO.	PART NO.	DESCRIPTION	REF. NO.	PART NO.	DESCRIPTION
1	732-0614	Wire Ring	34	719-0313	Lower Housing
2	716-0171	Retaining—Ring	35	718-0150	Anti-Rotation Brkt.
3	710-0854	Hex Bolt 1/4-20 x 1.75" Lg.*	38	712-0273	Hex Nut 5/16-24 Thd.
4	710-0809	Hex Tap Scr. 1/4-20 x 1.25" Lg.	39	736-0371	Fl-Wash. .344" I.D. x .875" O.D.
5	717-0764A	Upper Housing	40	717-0772A	Actuating Arm
8	711-0861	Input Shaft	41	761-0198	Brake Yoke
10	736-0335	Thrust Washer 5/8" I.D. x 1.25" O.D.	42	717-0682	Puck Plate
11	717-0633	Pinion Input 14T	43	717-0678	Brake Puck
12	716-0171	Retaining Ring	44	717-1022	Axle L.H. Ass'y.
13	717-0942	Drive Shaft—L.H. Brake	45	761-0202	Brake Disc
14	741-0336	Flange Brg. 5/8" I.D. x 3/4" Lg.*	46	741-0337	Flange Bearing 5/8" I.D. x 15/16" Lg.
15	717-1362	Bevel Gear 42T Small I.D.	48	611-0011	Shift Fork Ass'y.
16	717-1363	Bevel Gear 42T Large I.D.	49	741-0862	Ball Detent .250" Dia.
17	718-0228	Clutch Collar	50	732-0863	Spring Detent
18	717-1020	Miter Gear 15T (H.D.)	52	741-0335	Needle Brg. 5/8" I.D. x 1/2" Lg.
19	716-0184	Retaining Ring	54	736-0319	Fl-Wash. 5/8" I.D. x 1" O.D. x .020 Thk.
20	741-0589	Thrust Bearing	55	741-0313	Actuating Pin 5/16" Dia.
21	710-0862A	Pan Head Scr. 1/4-20 x .50" Lg. w/Patch	56	710-1206	Hex Wash. Hd. Self-Tap Scr. 1/4-20 Thd.
22	717-1023	Axle R.H. Ass'y.	57	717-1364	Differential Gear 58T
23	741-0340	Sleeve Bearing 3/4" I.D. x 1.0" Lg.	58	736-0349	Fl-Wash. 5/8" I.D. x 1" O.D. x .020 Thk.
24	721-0179	Oil Seal 3/4" I.D.		736-0495	Thrust Wash. 5/8" I.D. x 1" O.D. x .025" Thk.
25	750-0767	Axle Spacer	60	**	Washer (See Below)
26	736-0445	Fl-Wash. .760" I.D. x 1.5" O.D.	—	737-0148	Grease—Shell (15 oz.)
27	711-0918	Cross Shaft			
28	717-1252	Differential Can Ass'y.			
29	—	Part of Ref. 28			
32	**	Washer (See Below)			

**Ref. No. 32 736-0495 Thrust Wash. 5/8" I.D. x 1" O.D. x .025" Thk.
 736-0336 Fl-Wash. 5/8" I.D. x 1" O.D. x .030" Thk.
 736-0494 Thrust Wash. 5/8" I.D. x 1" O.D. x .035" Thk.
 736-0337 Fl-Wash. 5/8" I.D. x 1" O.D. x .040" Thk.

**Ref. No. 60 736-0492 Fl-Wash. .76" I.D. x 1.5" O.D. x .010" Thk.
 736-0493 Fl-Wash. .76" I.D. x 1.5" O.D. x .020" Thk.
 736-0351 Fl-Wash. .76" I.D. x 1.5" O.D. x .030" Thk.
 736-0445 Fl-Wash. .76" I.D. x 1.5" O.D. x .060" Thk.

TMO-3394704

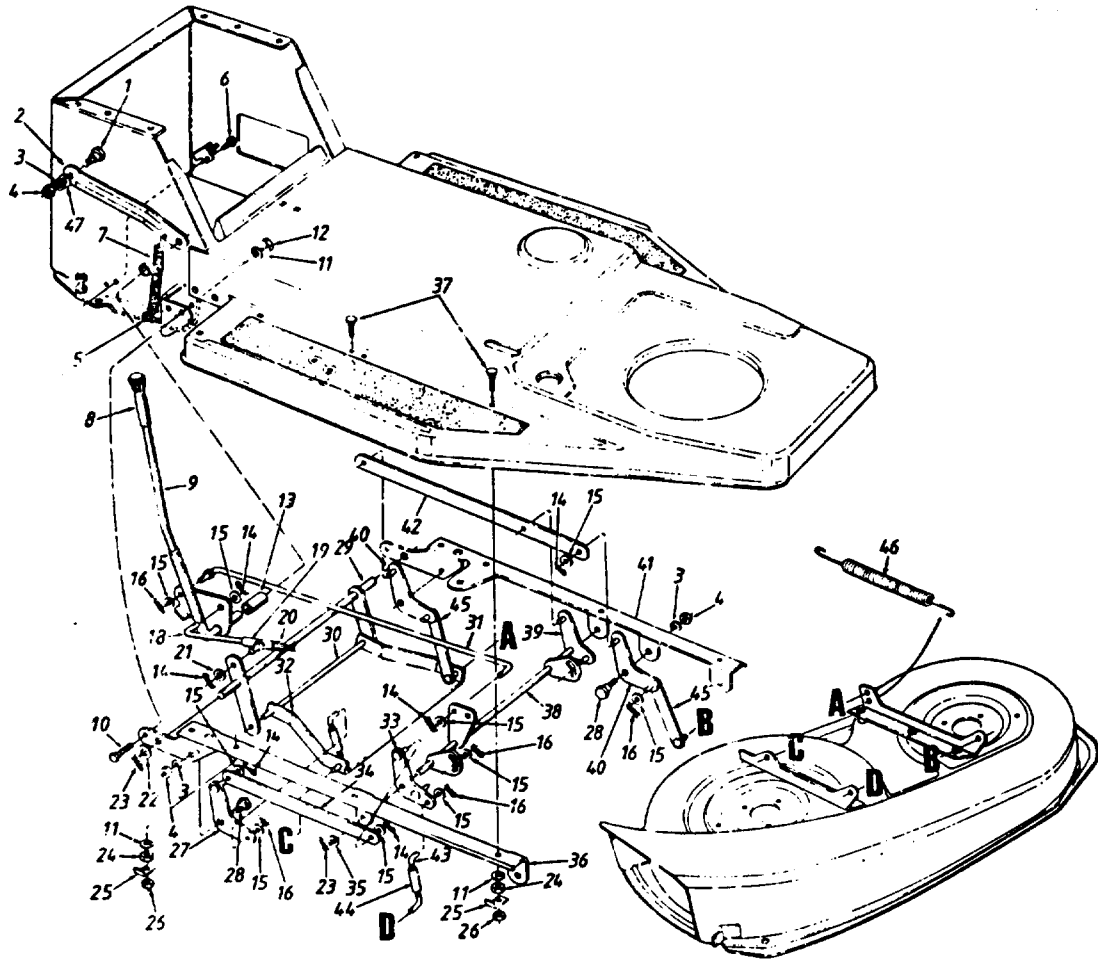

11.5 H.P. 38\"/>

REF. NO.	PART NO.	DESCRIPTION	REF. NO.	PART NO.	DESCRIPTION
1	738-0143	Shld. Bolt .5\"/>			
2	17580	Lift Handle Support Strap	25	17615	Harness Retainer
3	736-0169	L-Wash. 3/8\"/>			
4	712-0798	Hex Nut 3/8-16 Thd.*	26	712-0237	Hex Cent. L-Nut 5/16-24 Thd.
5	710-0428	Hex Bolt 1/4-28 x 1.25\"/>			
6	710-0599	Hex Wash. Hd. TT-Tap Scr. 1/4-20 x .5\"/>			
7	732-0640	Ext. Spring	27	17555	Deck Pivot Brkt. Ass'y.—R.H. Rear
8	720-0223	Grip	28	738-0281	Shld. Bolt .625\"/>
9	17591A	Deck Lift Handle Ass'y.	29	17574	Deck Link Shaft Ass'y.
10	710-0604	Hex Wash. TT-Tap Scr. 5/16-18 x .62\"/>			
11	736-0119	L-Wash. 5/16\"/>			
12	712-0267	Hex Nut 5/16-18 Thd.*	30	738-0667	Shaft 11.2\"/>
13	750-0379	Spacer 5/8\"/>			
14	714-0507	Cot-Pin 3/32\"/>			
15	736-0185	Fl-Wash. .406\"/>			
16	714-0104	Internal Cot-Pin 5/16\"/>			
18	747-0746	Deck Engagement Rod	31	747-0745	Deck Lift Rod
19	16682	Pivot Sleeve Ass'y.	32	17573	Deck Stabilizer Brkt.
20	712-0130	Hex L-Nut 3/8-16 Thd.	33	17554	Deck Pivot Brkt. Ass'y.—R.H. Front
21	736-0314	Thrust Washer .382\"/>			
22	736-0116	Fl-Wash. .635\"/>			
23	714-0470	Cot-Pin 1/8\"/>			
24	712-0123	Hex Nut 5/16-24 Thd.	34	17563	Connecting Link—R.H.
			35	736-0336	Fl-Wash. 5/8\"/>
			36	17582	Pivot Support Brkt.—R.H.
			37	710-1012	Rib Neck Bolt 5/16-24 x .84\"/>
			38	17568	Cross Shaft Ass'y.
			39	17557	Deck Pivot Brkt. Ass'y.—L.H.
			40	17556	Deck Pivot Brkt. Ass'y.—L.H.
			41	17581	Pivot Support Brkt.—L.H.
			42	17562	Connecting Link—L.H.
			43	747-0584	Lift Link 3/8-24 x 1.25\"/>
			44	17709	Adj. Lift Link Ass'y.
			45	17598	Deck Lift Link Ass'y.
			46	732-0564	Deck Spring 10.33\"/>
			47	736-0192	Fl-Wash. .531\"/>

TMO-3394704

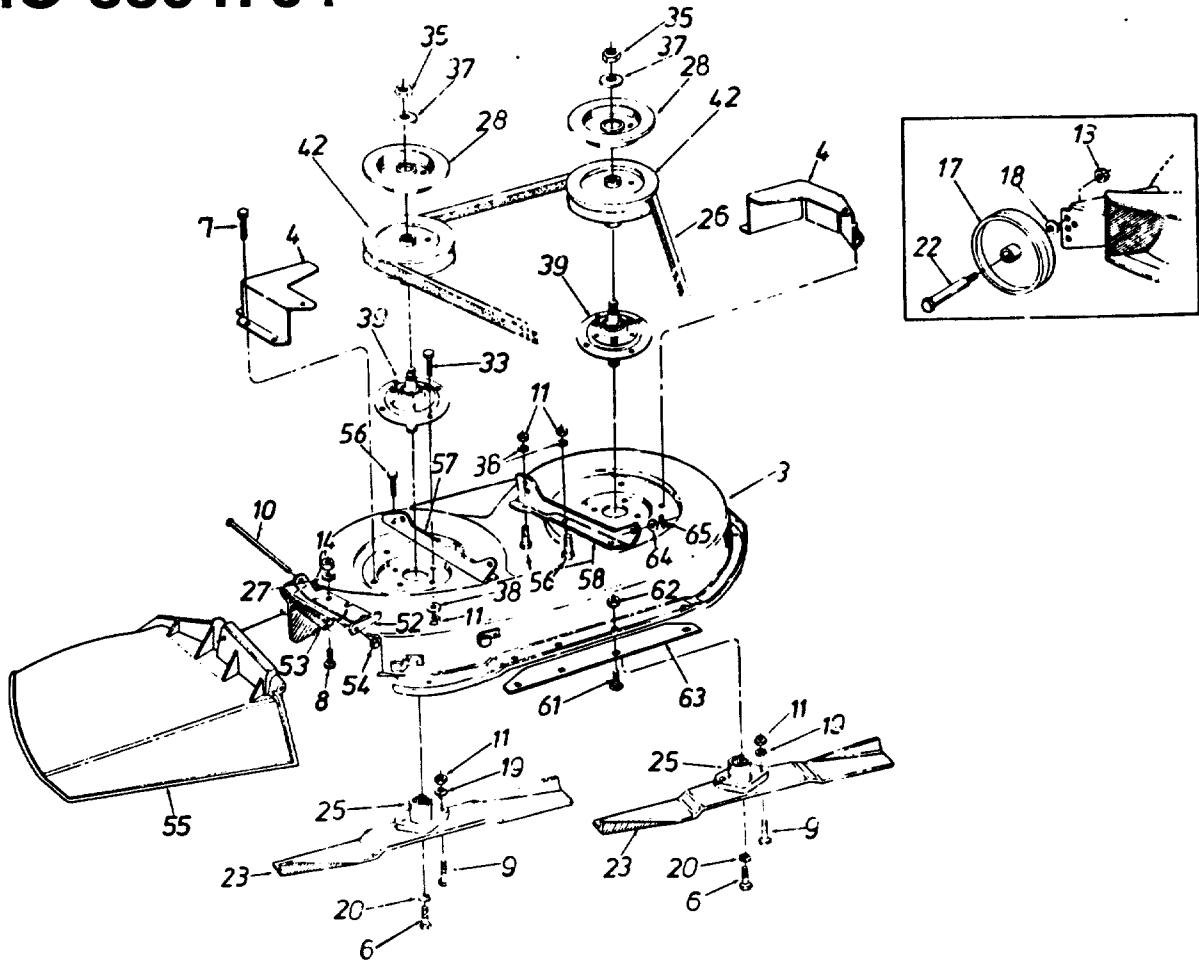

**11.5 H.P. 38" LAWN TRACTOR
PARTS LIST FOR MODEL TMO-3394704**

REF. NO.	PART NO.	DESCRIPTION	REF. NO.	PART NO.	DESCRIPTION
3	17717A 813-04119	38" Deck Ass'y. 38" Deck Ass'y. Comp. (For Service Only)	35	712-0318	Hex Jam Nut 5/8-18 Thd.
4	17665	Belt Guard Deck	37	736-0158	L-Wash 5/8" I.D.*
6	710-0152	Hex Bolt 3/8-24 x 1.0" Lg.	38	736-0242	Bell-Wash. .345" I.D. x .88" O.D.
7	710-0599	Hex Wash. Hd. TT-Tap Scr. 1/4-20 Thd.	39	717-0906	Blade Spindle Ass'y. Comp. (Incl. Ref. 33)
8	710-0258	Hex Bolt 1/4-20 x .62" Lg.	42	756-0486	5" Dia. Pulley
9	710-0888	Hex Bolt Special 5/16-24 x 1.0"	52	703-1693	Hinge Mtg. Brkt.
10	711-0792	Hinge Pin	53	732-0602	Torsion Spring
11	712-0123	Hex Nut 5/16-24 Thd.*	54	726-0106	Push Nut
14	712-0257	Hex Nut 1/4-20 Thd.*	55	731-1032	Chute Ass'y. Comp.
19	736-0119	L-Wash. 5/16" I.D.*	56	710-0157	Hex Bolt 5/16-24 x .75" Lg.
20	736-0217	L-Wash. 3/8" I.D.—H.D.	57	17572	Deck Hanger Channel—R.H.
23	742-0473A	High-Lift Blade	58	17571	Deck Hanger Channel—L.H.
25	748-0300	Blade Adapter	61	710-0167	Carr. Bolt 1/4-20 x .5" Lg.
26	754-0329A	V-Belt	62	712-0271	Hex Sems Nut 1/4-20 Thd.
27	736-0270	Bell-Wash. 1/4" I.D.	63	17565	Deck Skirt Ext.
28	09322	Brake Disc	64	736-0185	Fl-Wash. .406" I.D. x .73" O.D.
33	710-0157	Hex Bolt 5/16-24 x .75" Lg.	65	714-0104	Hairpin Clip 3/8" Dia.

*Common Hardware—May be purchased locally.
IMPORTANT: DO NOT order parts by reference number (Ref. No.).

SERVICE NATIONWIDE

Montgomery Ward

**HOW TO OBTAIN
REPLACEMENT PARTS AND SERVICE**

The merchandise you have purchased from us has been carefully engineered and manufactured under Montgomery Ward's rigid quality standards and should give you satisfactory and dependable operation. However, like all mechanical merchandise, it may occasionally require adjustment, replacement parts or maintenance.

Toll Free Parts Sales Center

When you need a replacement part or accessory for a major appliance, home electronic item or lawn and garden product that is not under warranty or covered by a service contract or if you need the location of the nearest service facility, call our Parts Sales Center toll free 1-800-323-1965.

Provide the following:

1. Model, serial number and all of the other data shown on the model plate.
2. Also give the part number or numbers as shown in the parts list that came with the product.

Replacement Parts will be made available at current prices. If requested, prices will be quoted in advance when not listed.

If you order parts by mail, you will pay the transportation charges from the shipping point.

UNIT MODEL NO. _____

UNIT SERIAL NO. _____

ENGINE MODEL NO. _____

TYPE NO. _____

CODE NO. _____